

Wiringkit

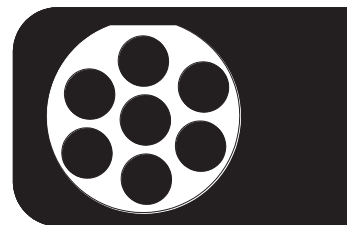

D	Einbauanleitung
GB	Installation instructions
F	Consignes de montage
NL	Montagehandleiding
DK	Montagevejledning
N	Monteringsinstruksjon
S	Installationsanvisning
FIN	Asennusohje
I	Istruzioni per il montaggio
E	Instrucciones de montaje
P	Instruções de montagem
GR	Οδηγίες εγκατάστασης
CZ	Návod k montáži
SLO	Navodilo za vgradnjo
SK	Montážny návod
PL	Instrukcja montażu
TR	Montaj talimatı
H	Beépítési útmutató
HR	Upute o ugradnji
BUL	Инструкция за монтаж
RO	Instrucțiuni de montaj
RU	Инструкция по монтажу и установке
LT	Montavimo informacija
LV	Iemontēšanas pamācība
EST	Paigaldusjuhend

766133 UNIVERSAL

- Expert 7 - pin
- Expert 7 - polig
- Expert 7 – polige

KIT

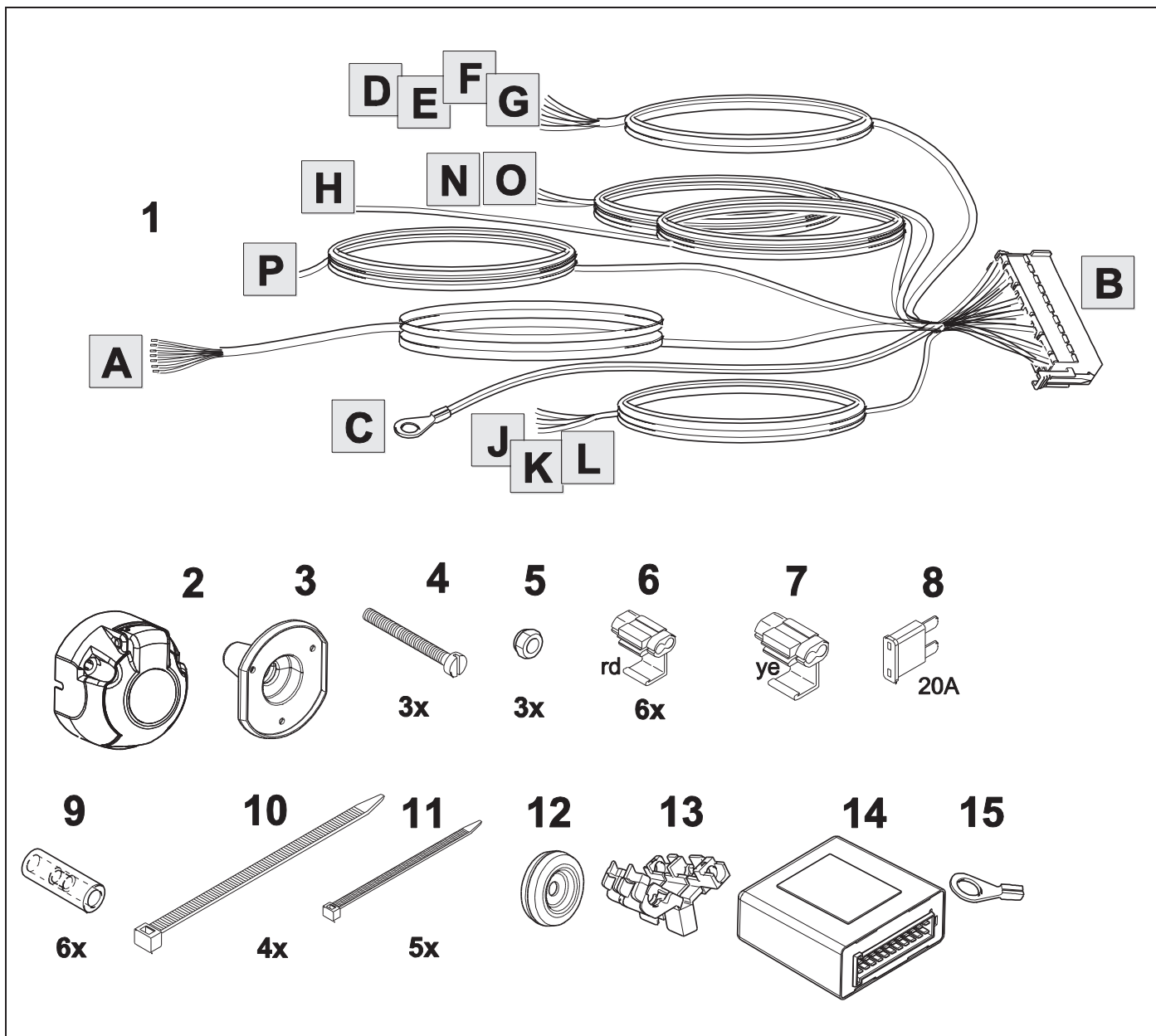

TOOLS

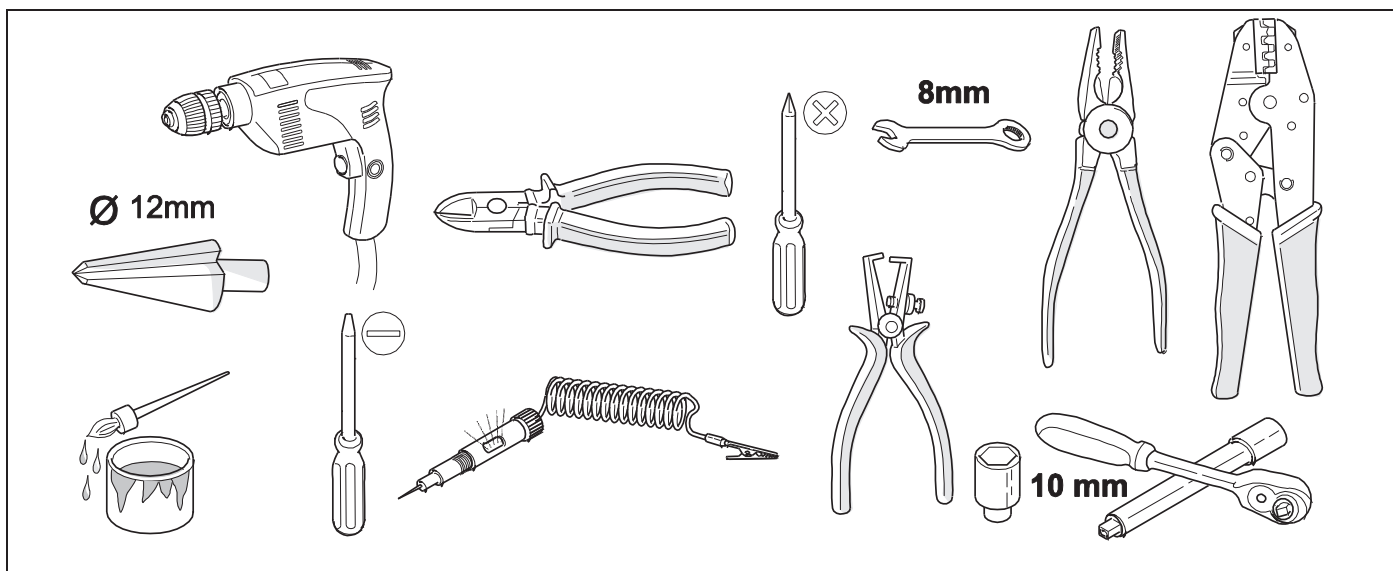

1

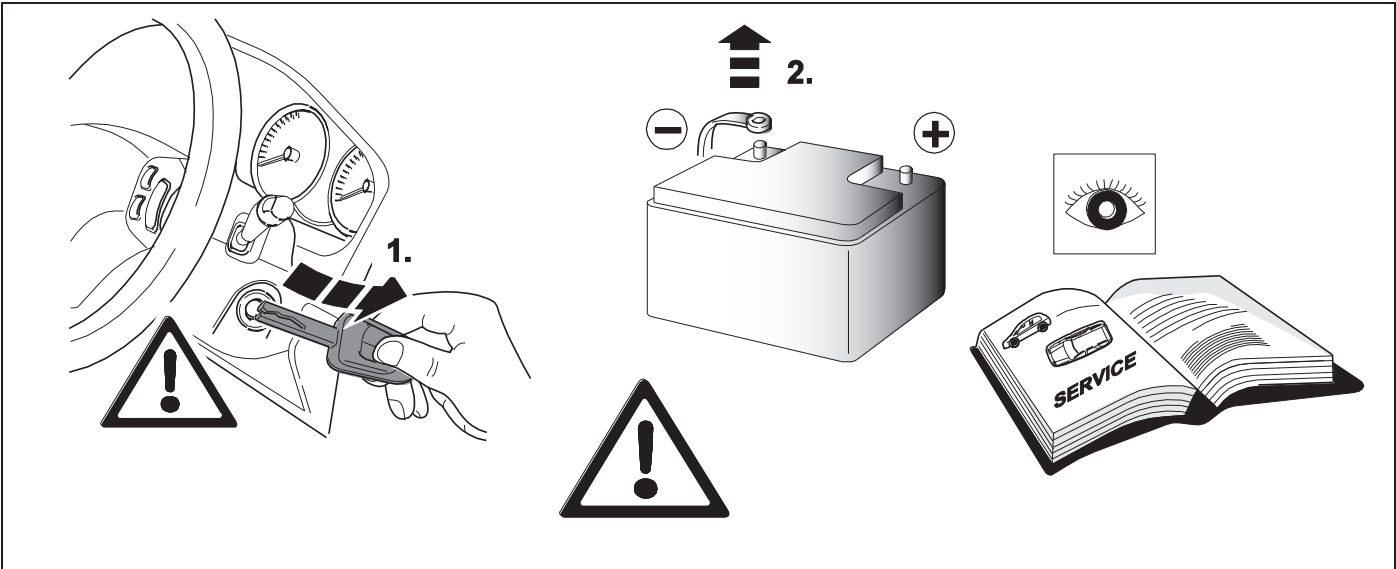

2

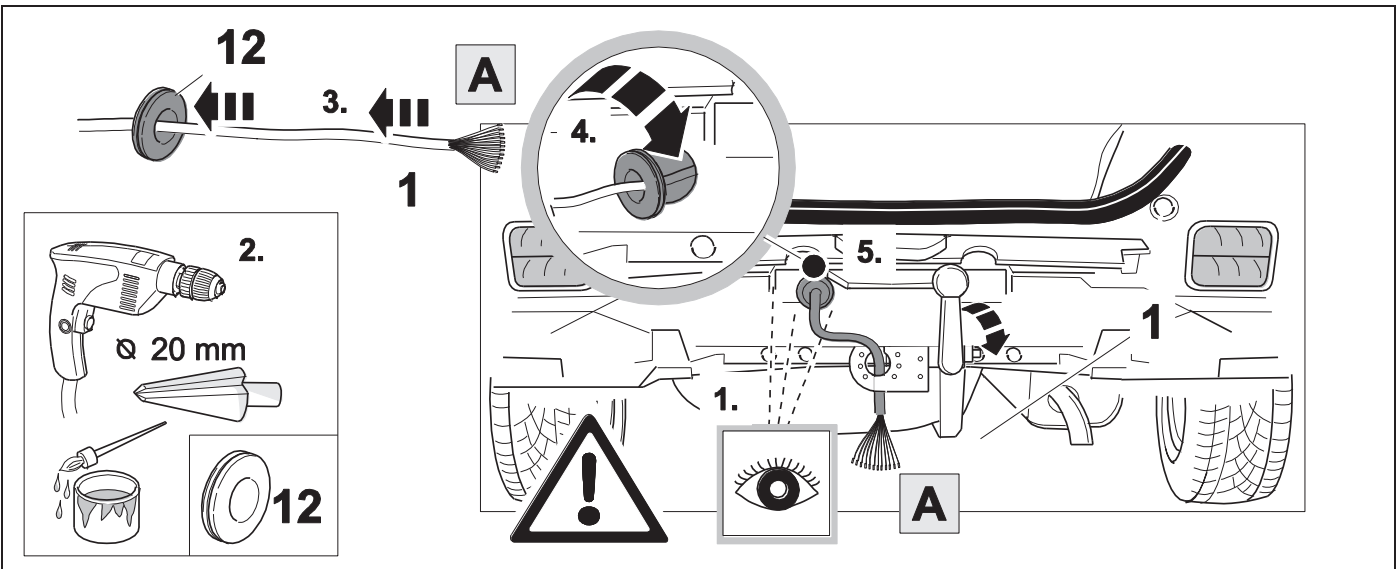

3

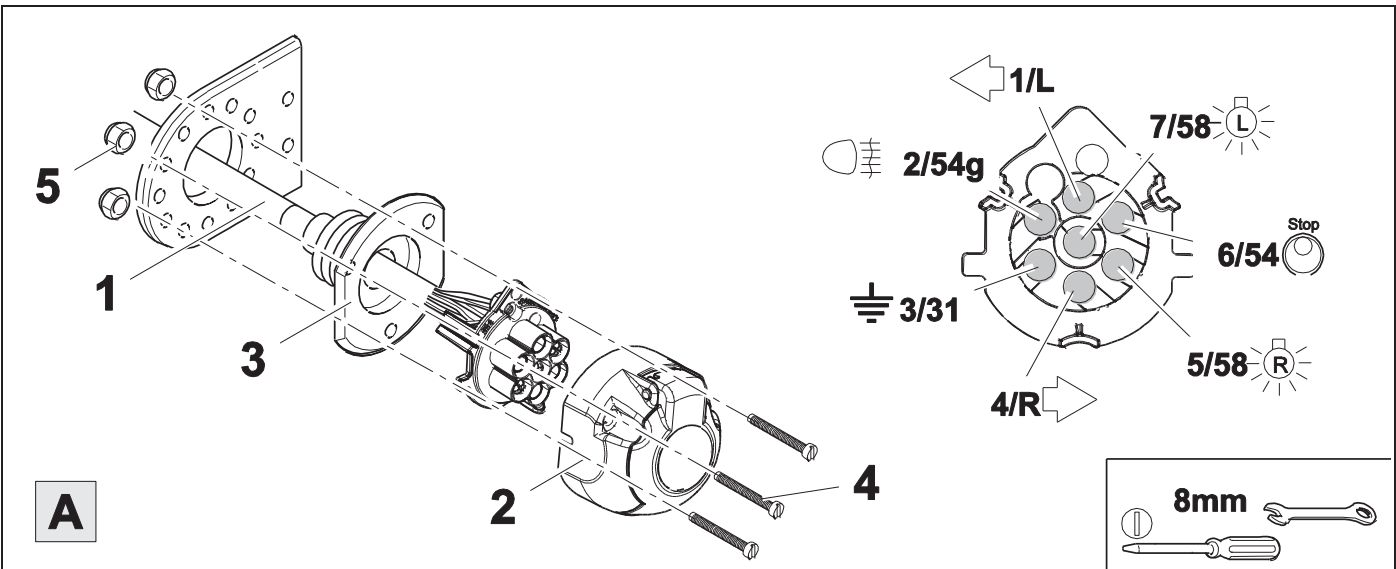

4



5

1/L	ye	
2/54g	bu	
3/31	wh	
4/R	gn	
5/58R	bn	
6/54	rd	
7/58L	bk	

5	bk	wh	gy	gn	rd	bu	ye	bn	pu	or
	schwarz	weiß	grau	grün	rot	blau	gelb	braun	violett	orange
	black	white	grey	green	red	blue	yellow	brown	purple	orange
	noir	blanc	gris	vert	rouge	bleu	jaune	brun	violet	orange
	zwart	wit	grijs	groen	rood	blauw	geel	bruin	violet	oranje
	sort	hvid	grå	grøn	rød	blå	gul	brun	violet	orange
	svart	hvit	grå	grønn	rød	blå	gul	brun	fiolett	oransje
	svart	vit	grå	grön	röd	blå	gul	brun	violett	orange
	musta	valkoinen	harmaa	vihreä	punainen	sininen	keltainen	ruskea	violetti	oranssi
	nero	bianco	grigio	verde	rosso	blu	giallo	marrone	viola	arancione
	negro	blanco	gris	verde	rojo	azul	amarillo	marrón	violeta	anaranjado
	preto	branco	cinzento	verde	vermelho	azul	amarelo	castanho	violeta	laranja
	μαύρος	λευκός	Γκρι	πράσινος	κόκκινος	μπλε	κίτρινος	καφέ	Μωβ	πορτοκαλί
	czarny	biały	szaro	zielony	czerwony	niebiesko	żółty	brazowy	fioletowy	pomarańczowy
	černý	bílý	šedý	zelený	červený	modrý	žlutý	hnědý	fialový	oranžový
	siyah	beyaz	gri	yeşil	kırmızı	mavi	sarı	kahverengi	mor	portakal rengi
	fekete	fehér	szürke	zöld	piros	kék	sárga	barna	ibolyakék	narancssárga
	crno	bijelo	sivo	zeleno	crveno	plavo	zuto	smeđe	ljubičasto	narandasto
	черен	бял	сив	зелен	червен	син	жълт	кафяв	виолетов	оранжев
	negru	alb	gri	verde	roșu	albastru	galben	maro	violet	portocaliu
	черный	белый	серый	зеленый	красный	голубой	жёлтый	коричневый	пурпур-ный	оранжевый
	juoda	balta	pilka	žalia	raudona	mėlyna	geltona	ruda	purpurinė	oranžinė
	melna	balta	pelēka	zaļa	sarkana	zila	dzeltena	brūna	purpur-sarkana	oranža
	must	valge	hall	roheline	punane	sinine	kollane	pruun	purpur-punane	oraanž
	črna	bela	siva	zelena	rdeča	modra	rumena	smeđ	vijoličast	oranžen
	čierny	biely	šedý	zelený	červený	modrý	žltý	hnedý	fialový	pomarančový

6

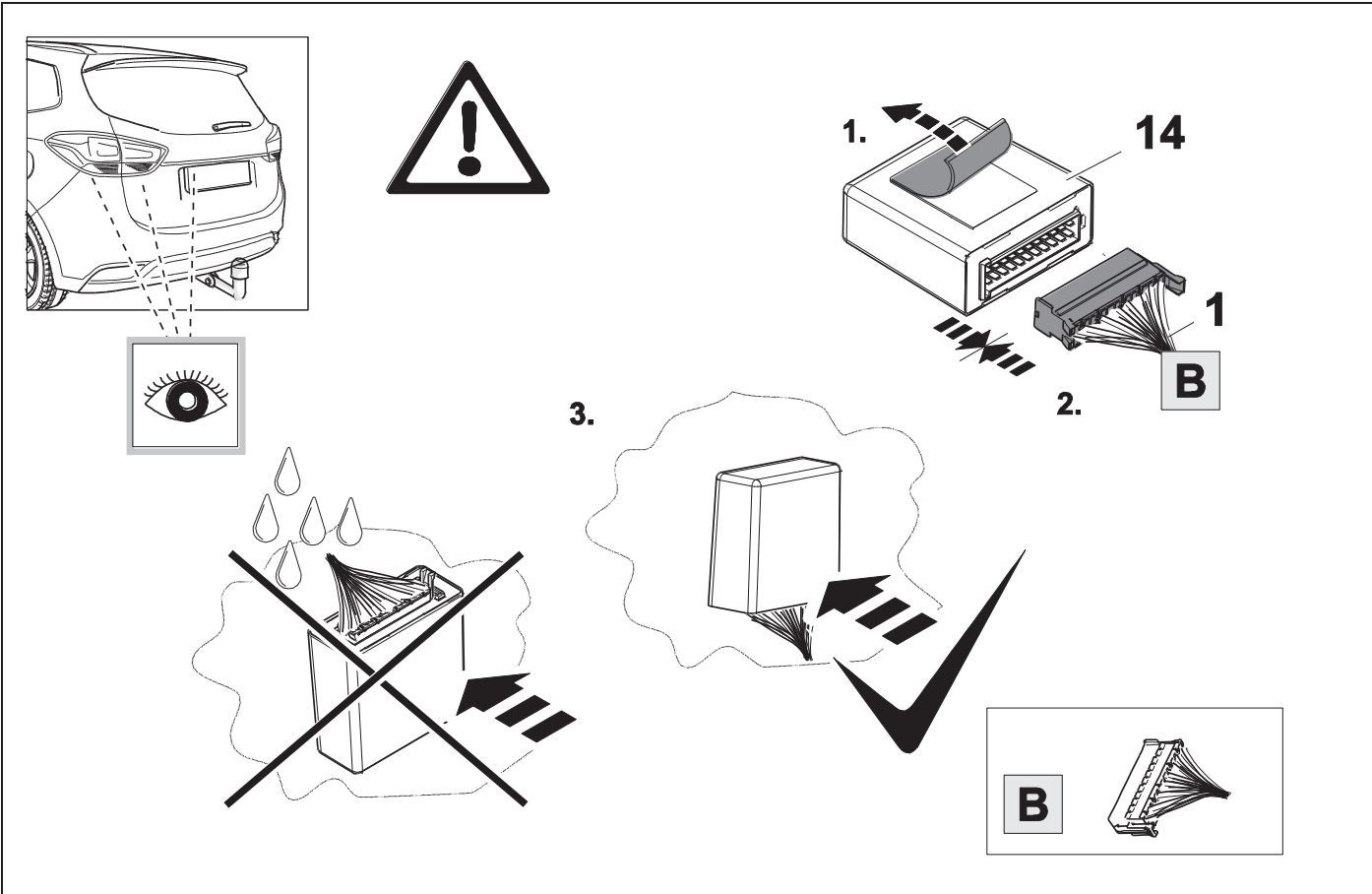

7

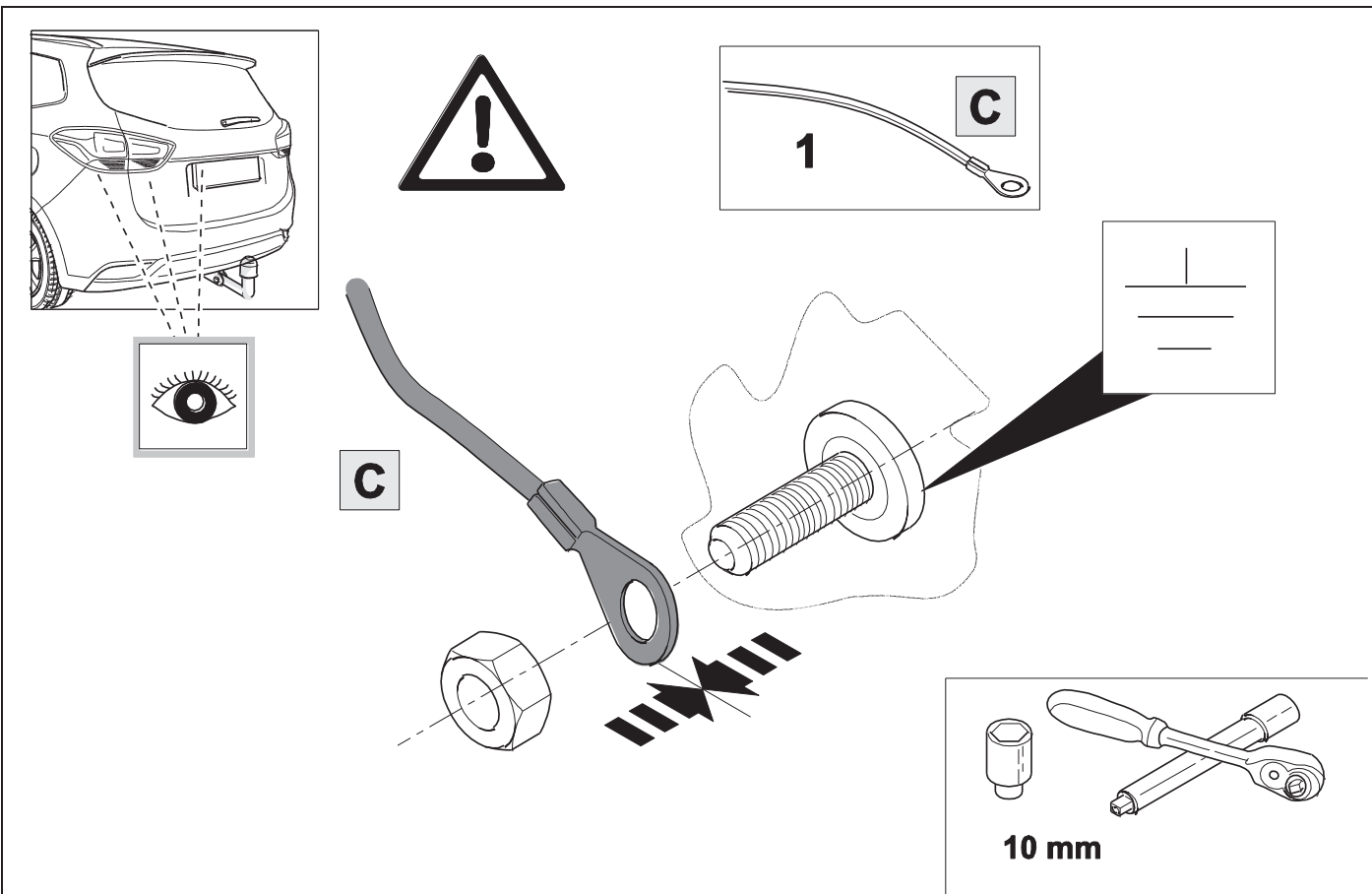

8 WITHOUT TRAILER FLASHER CONTROL OPTION 1A

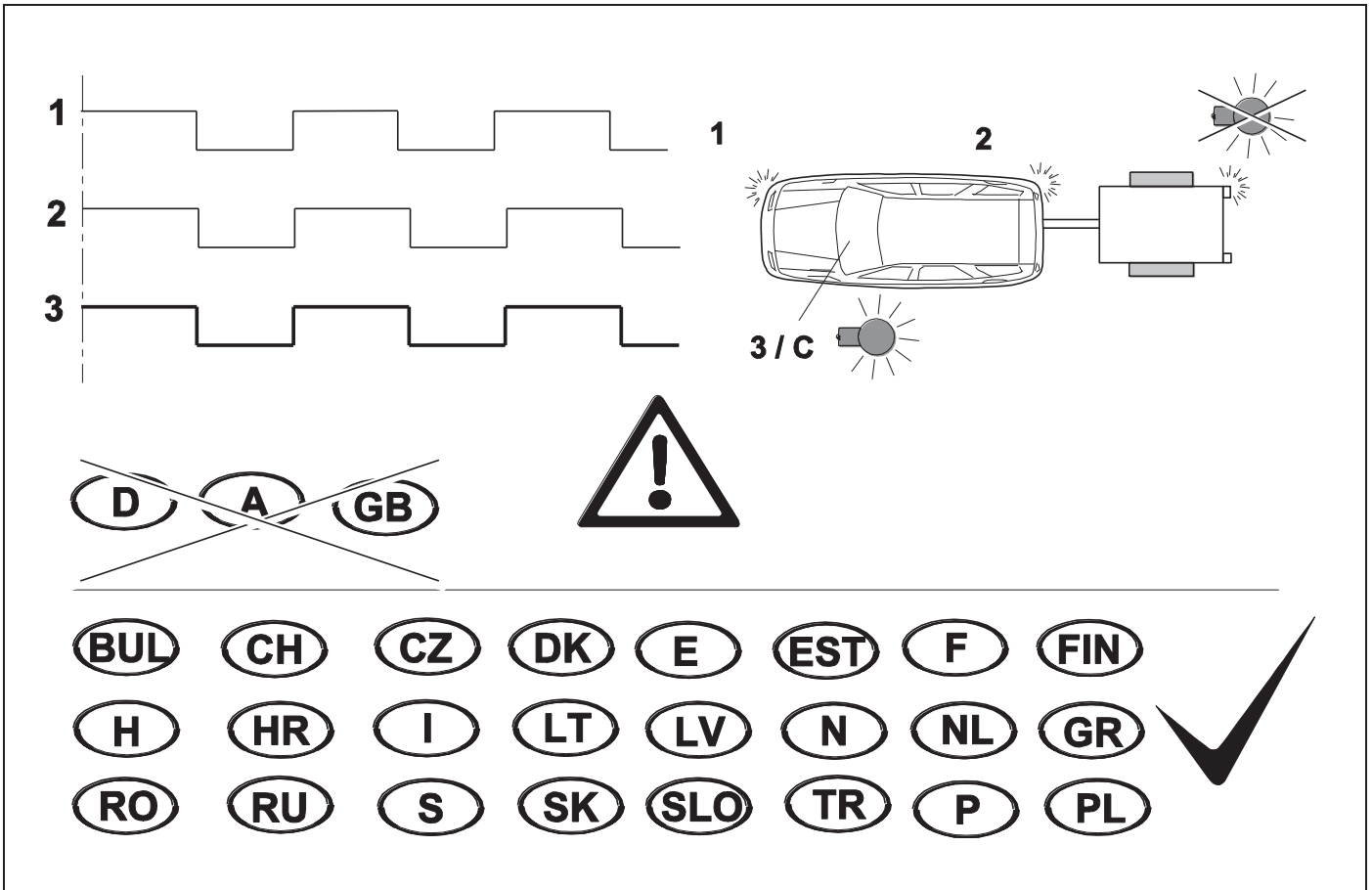

9



5

OPTION 1A

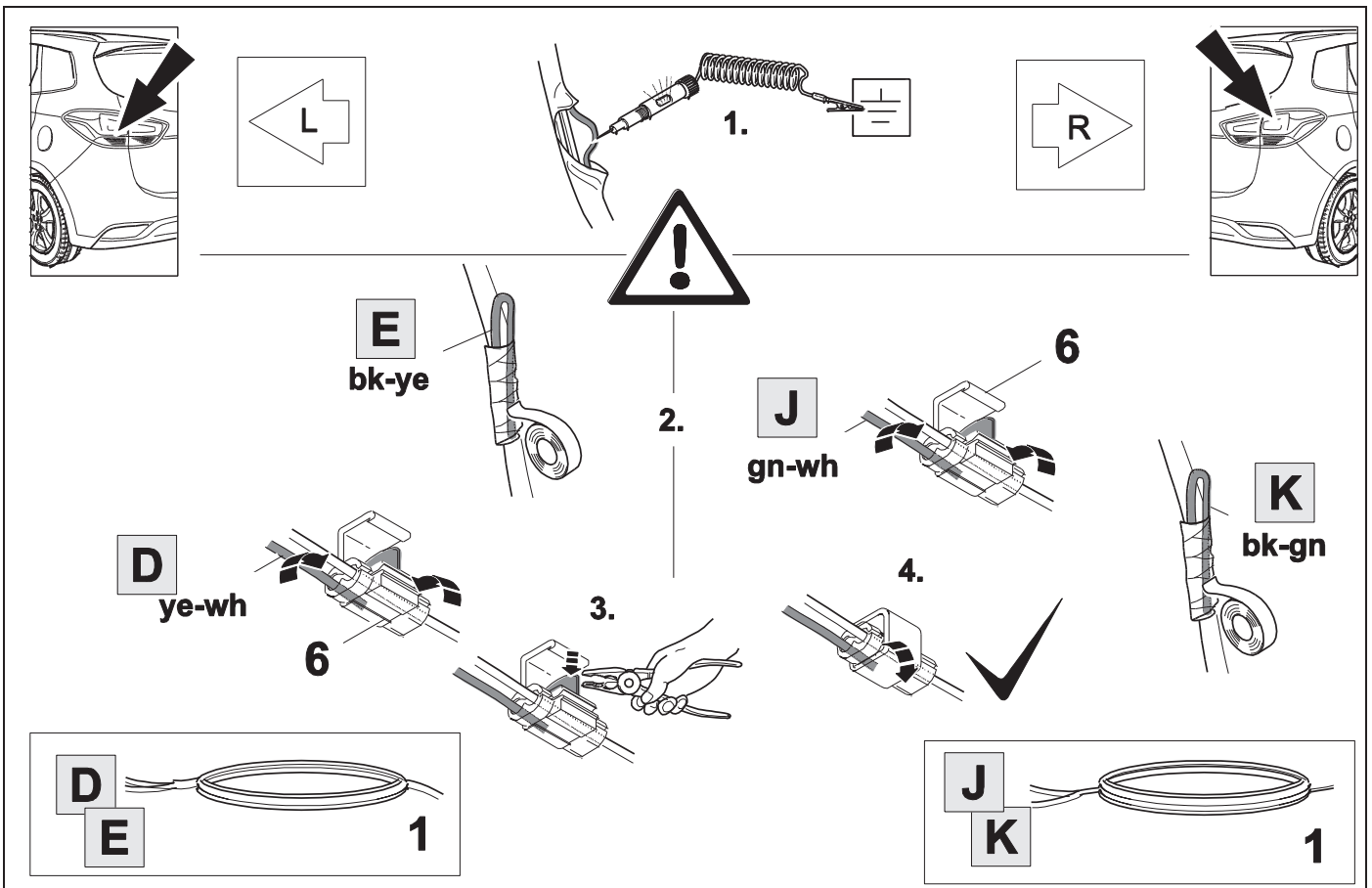

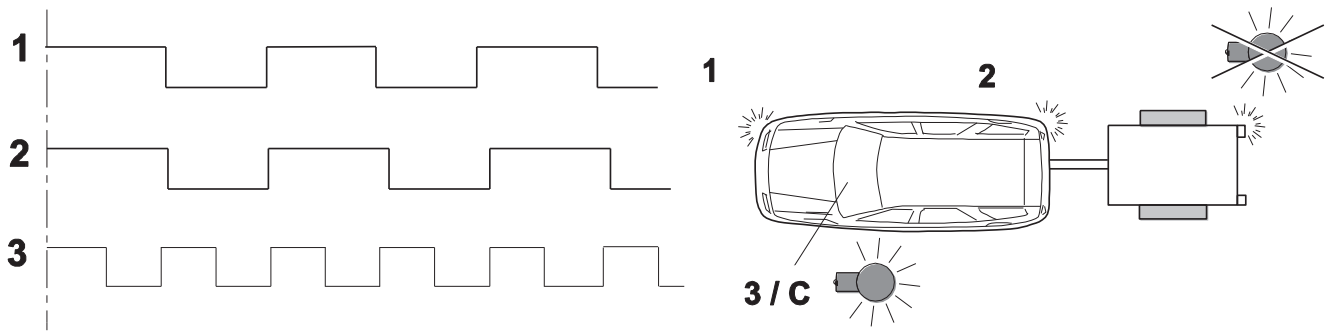

D A GB



BUL CH CZ DK E EST F FIN
H HR I LT LV N NL GR
RO RU S SK SLO TR P PL

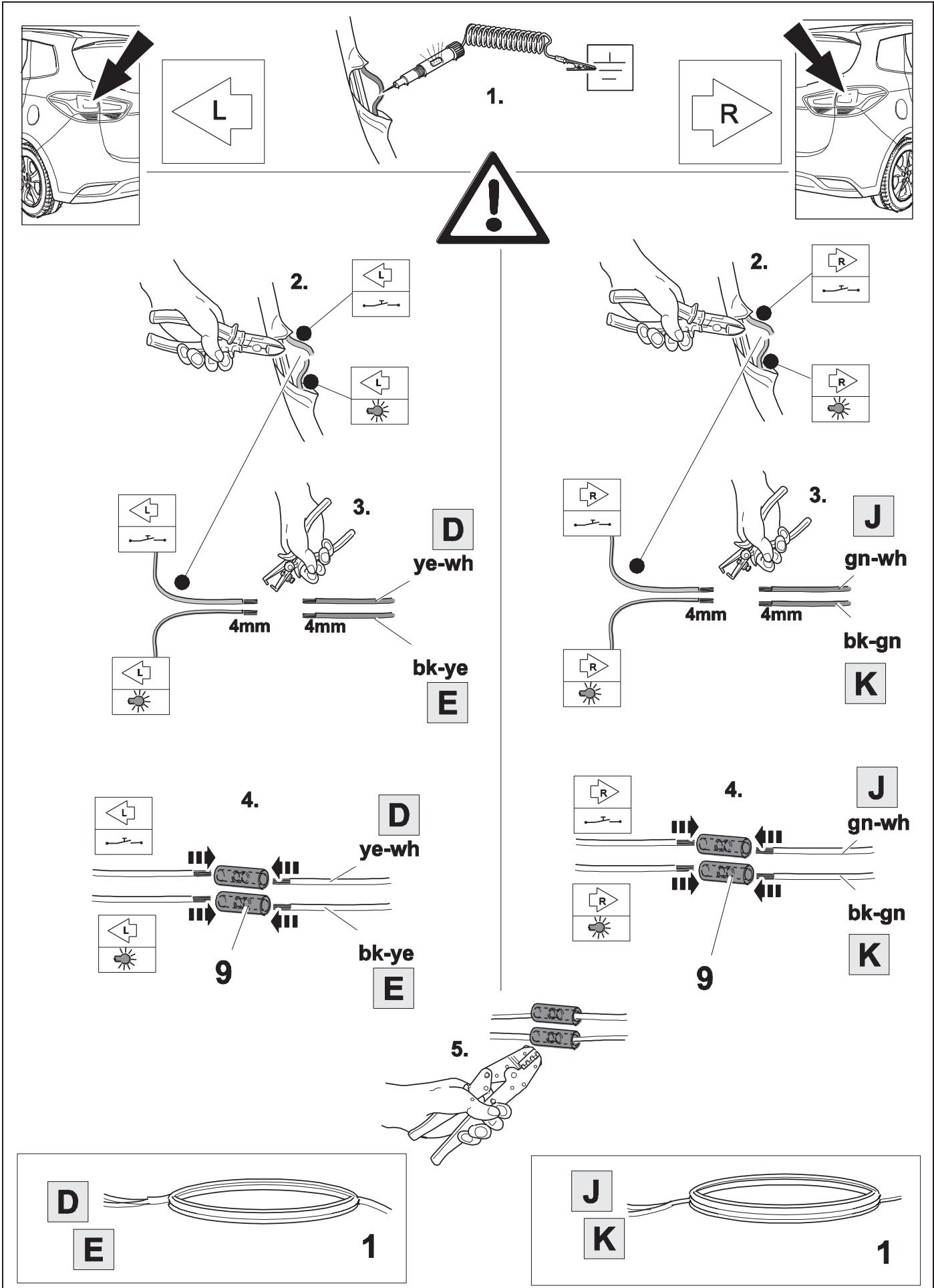

12 WITHOUT MULTIPLEX - SYSTEM / PWM OPTION 2A

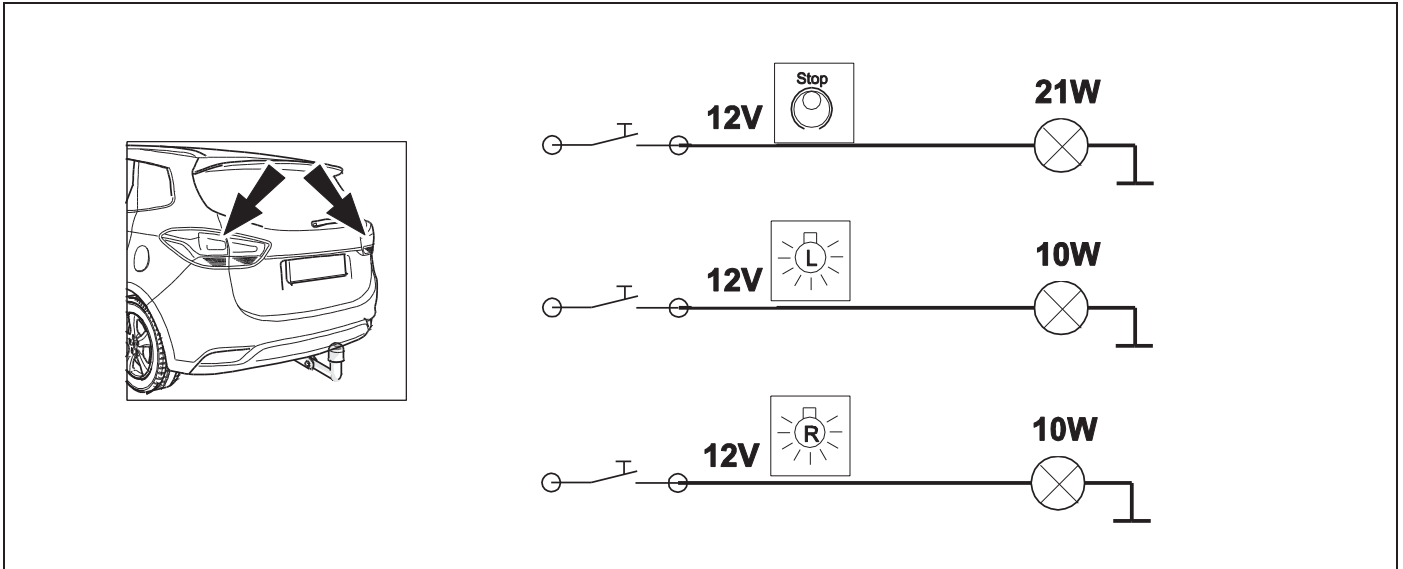

13



OPTION 2A

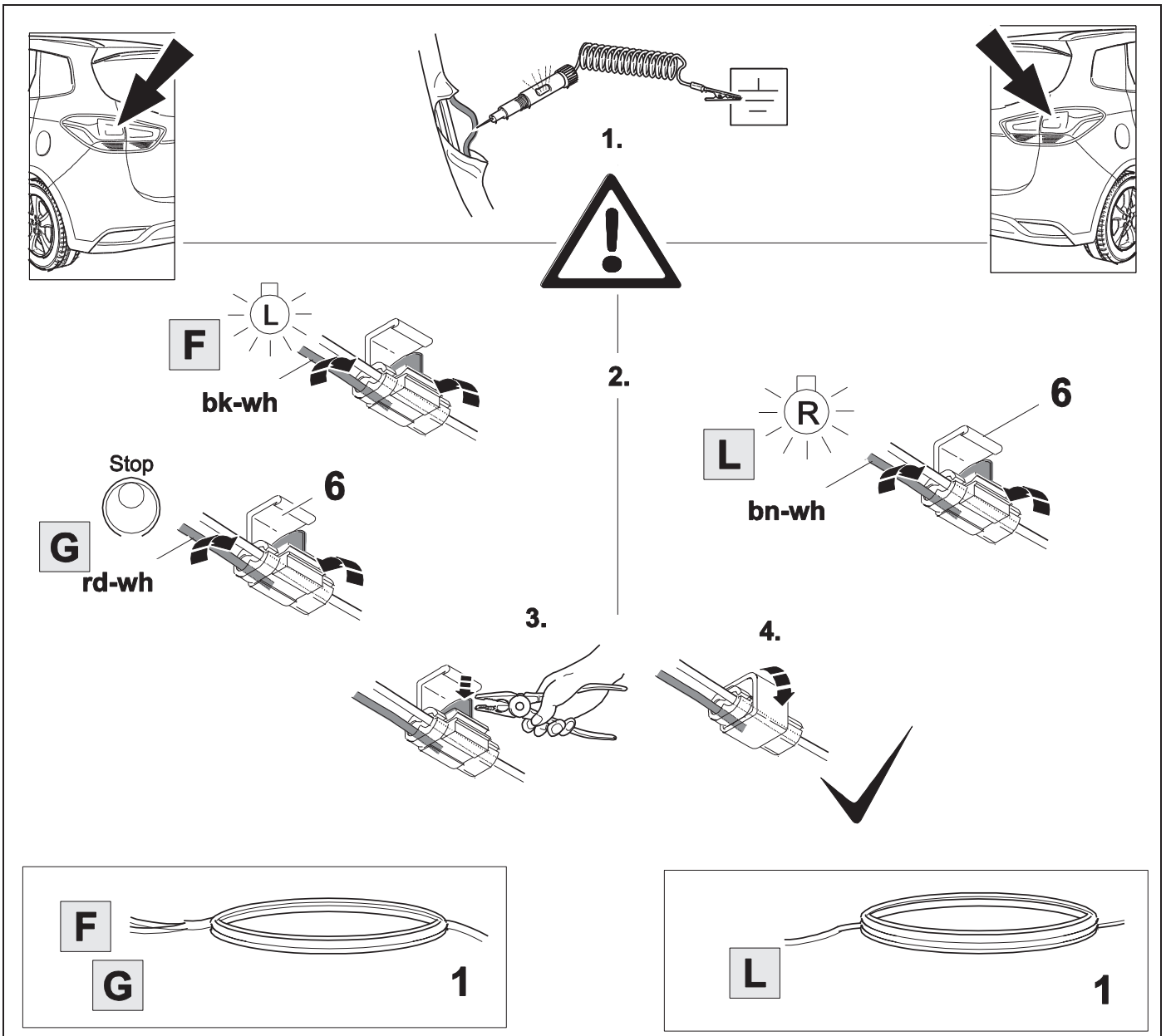

14

WITH MULTIPLEX - SYSTEM / PWM

OPTION 2B

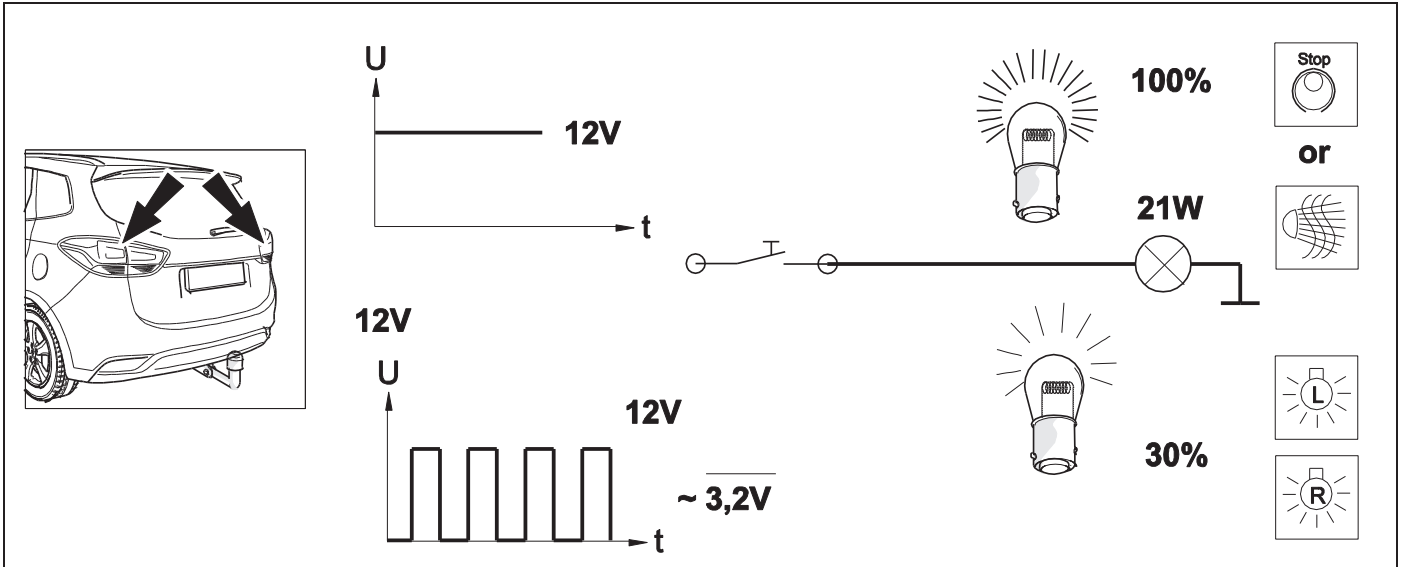

15

5

OPTION 2B

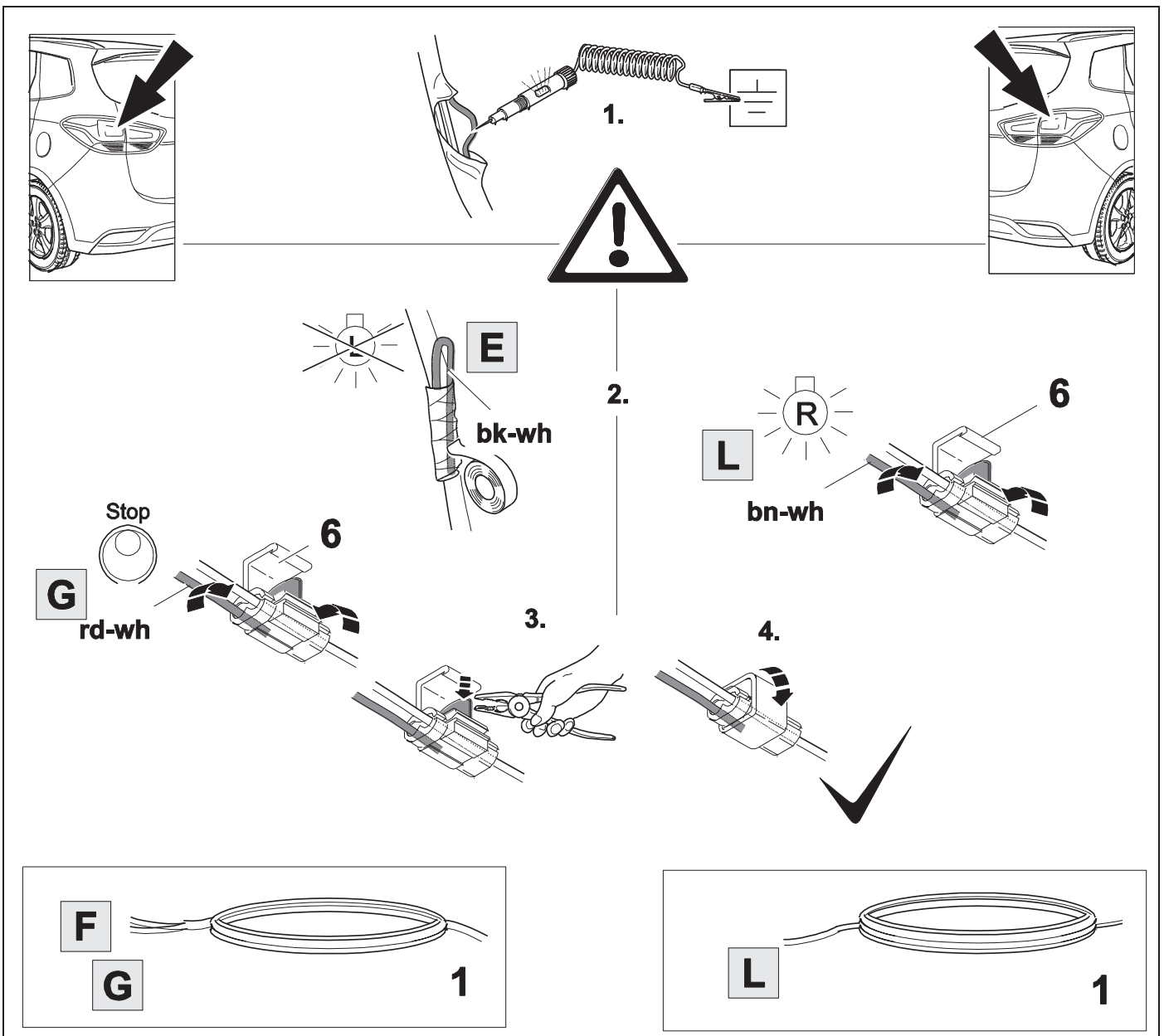

16 POLARITY FOG LAMP (POSITIVE OR NEGATIV SWITCHED)

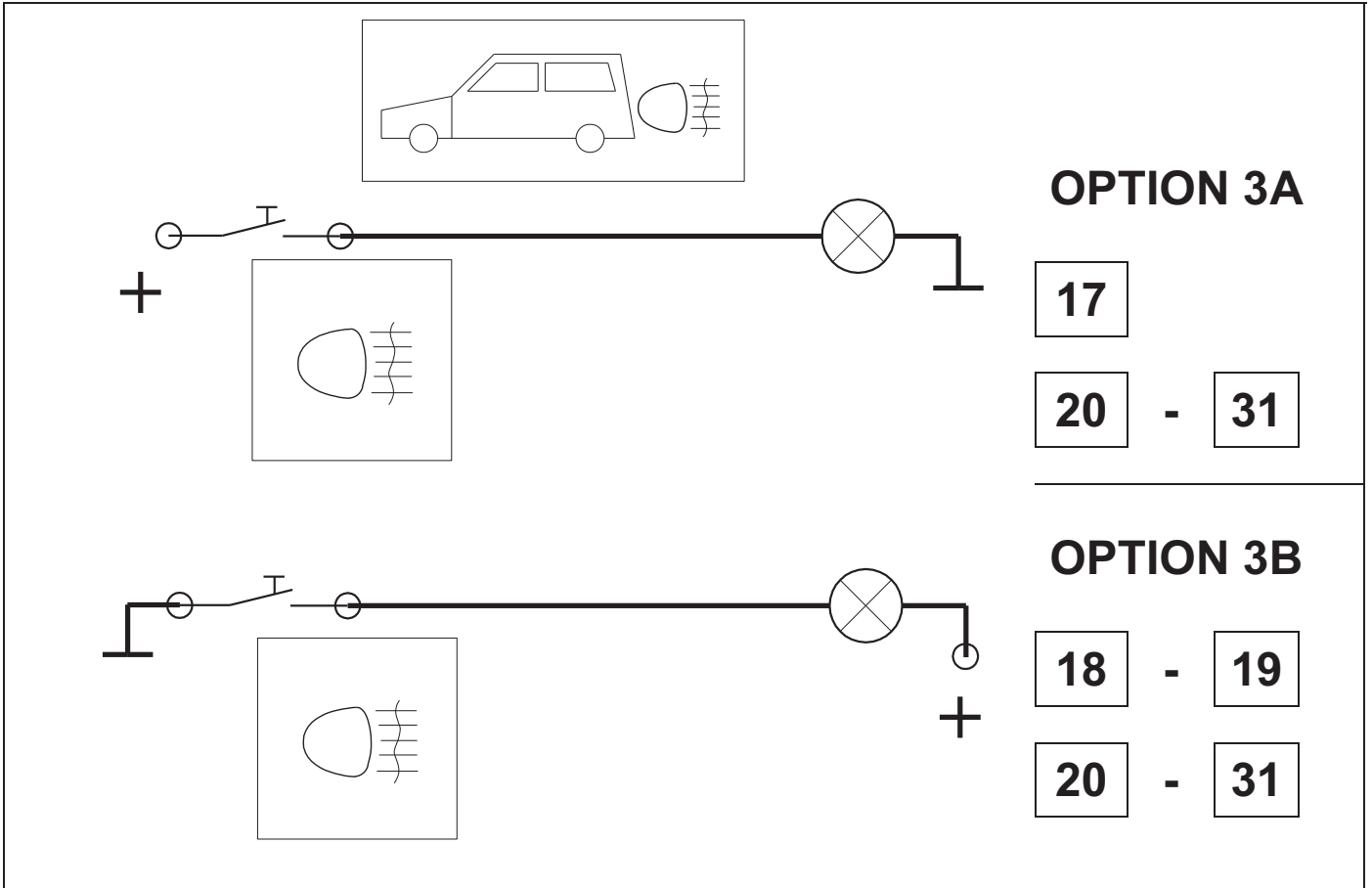

17 POSITIVE SWITCHED



5

OPTION 3A

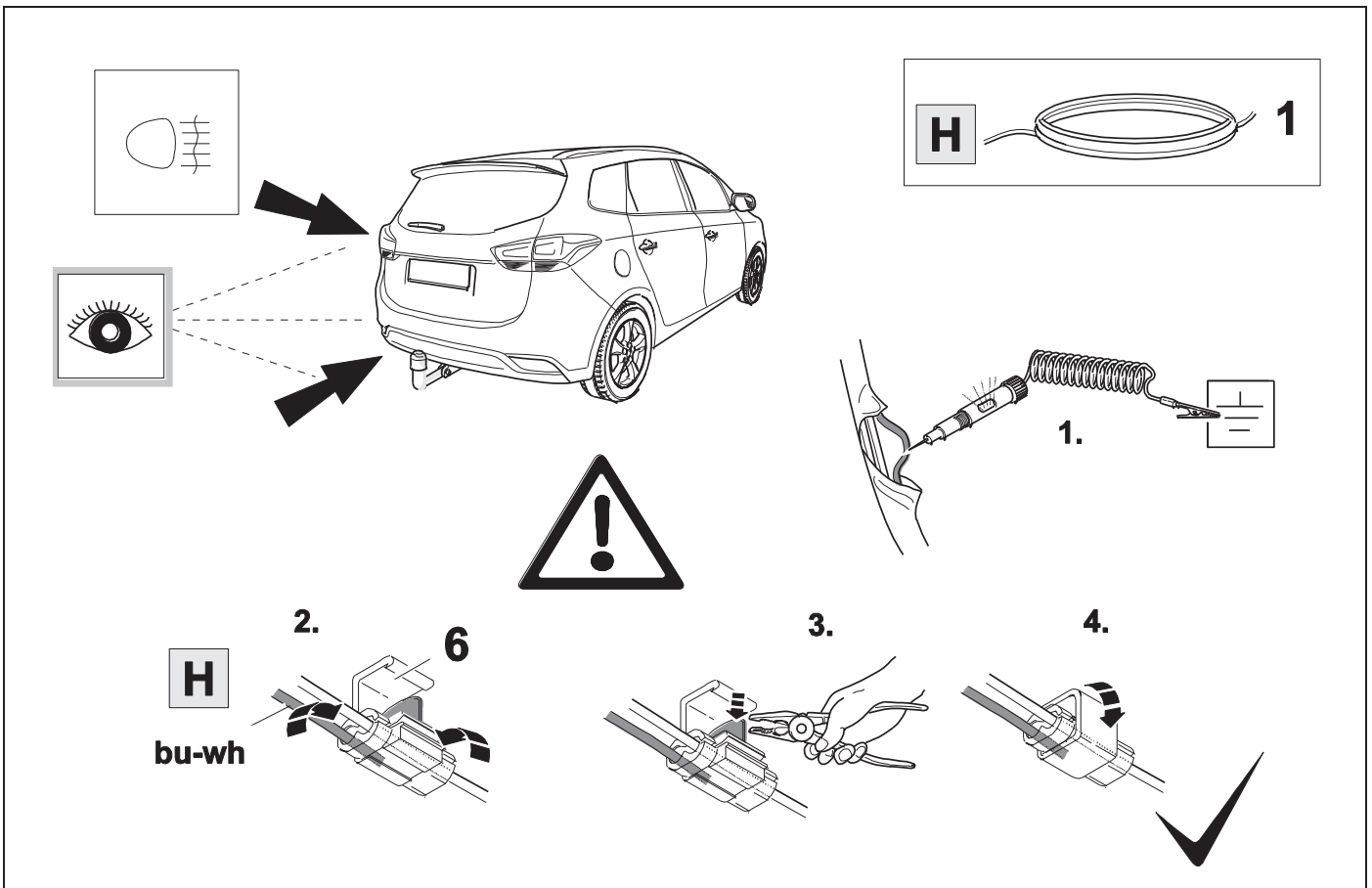

18 NEGATIVE SWITCHED  ⇨

5

OPTION 3B

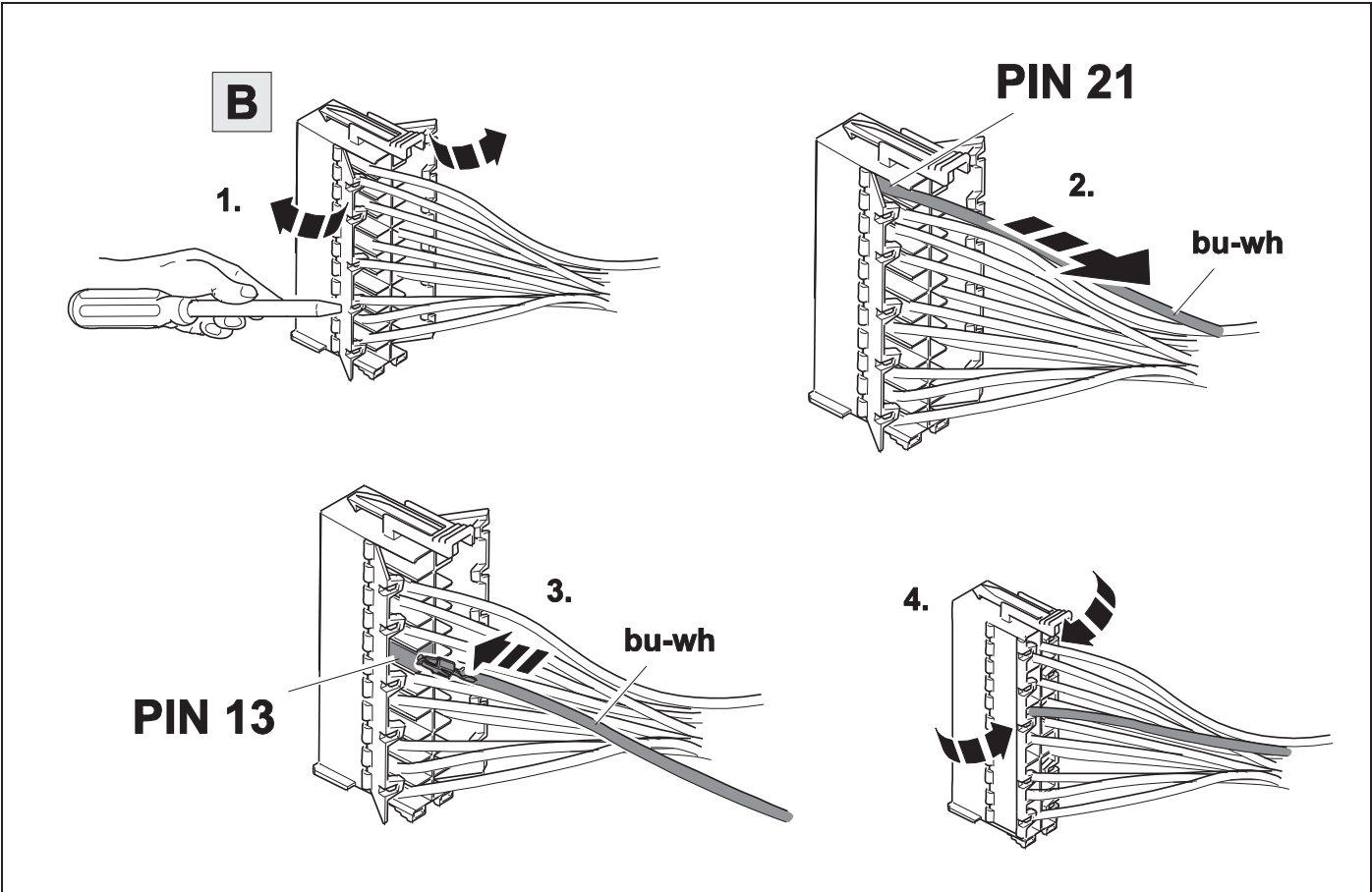

19 NEGATIVE SWITCHED  ⇨

5

OPTION 3B

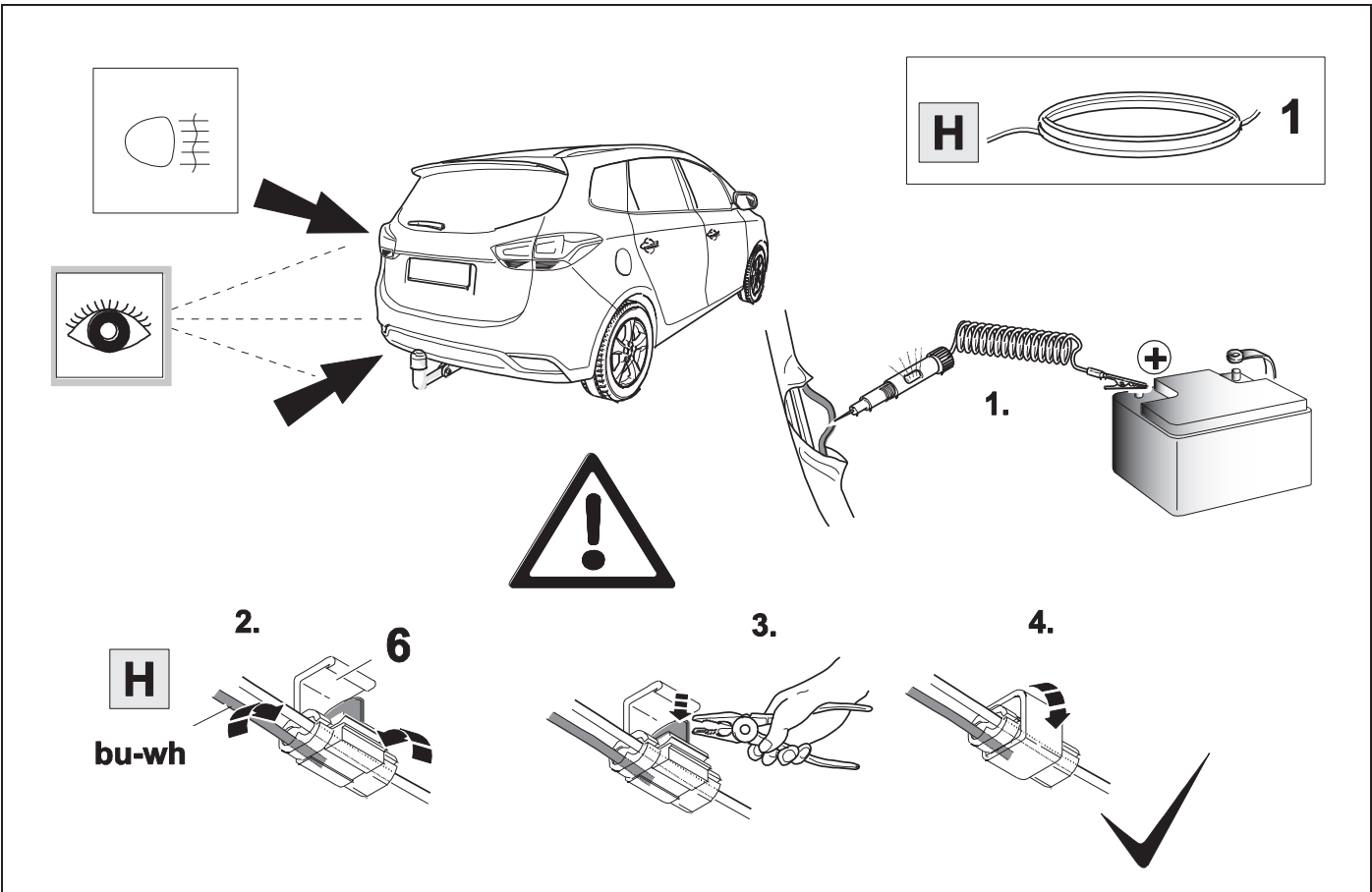

20

👁️ ⇒ 5

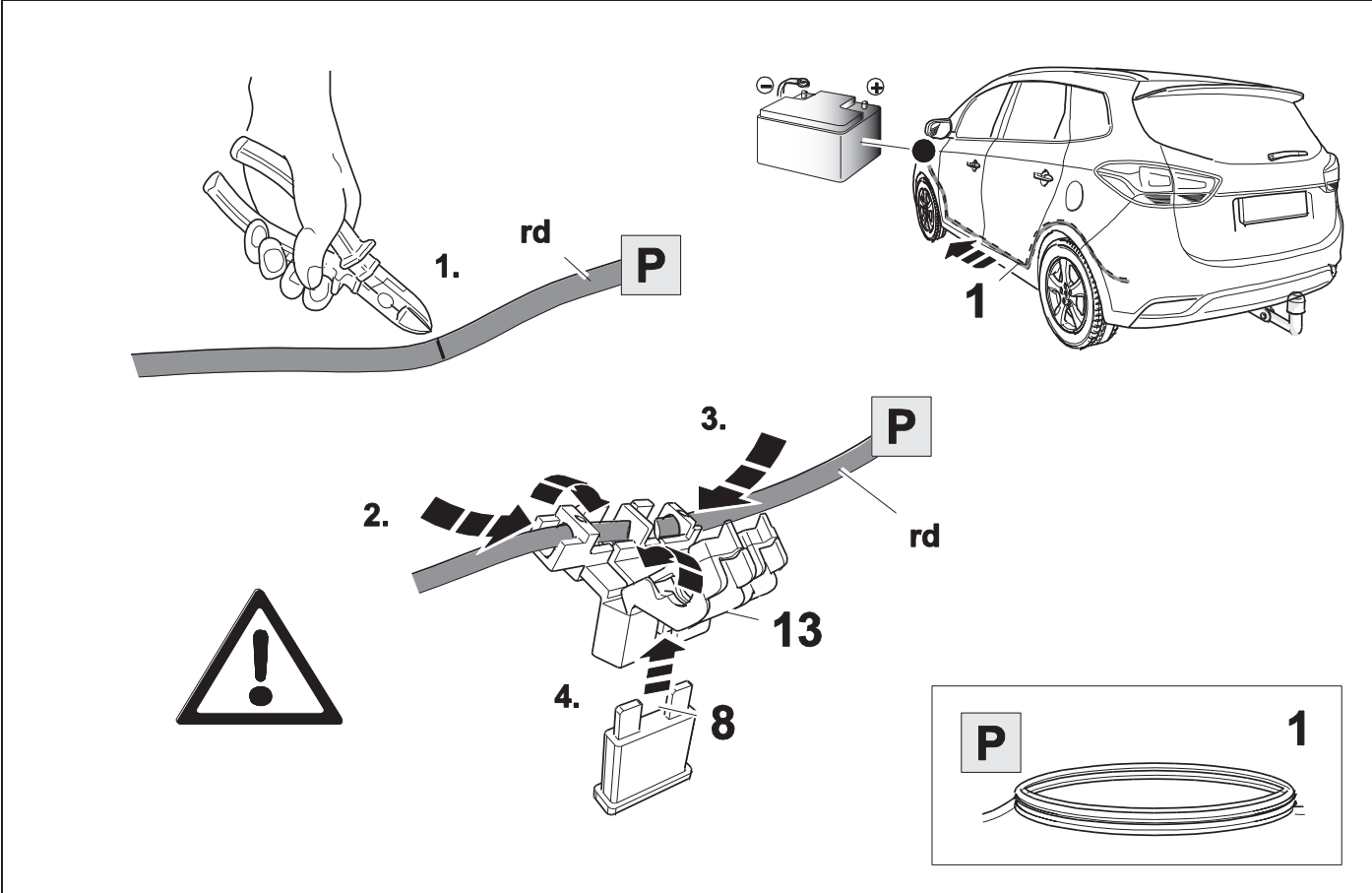

21

OPTION 4A

👁️ ⇒ 5

OPTION 4B

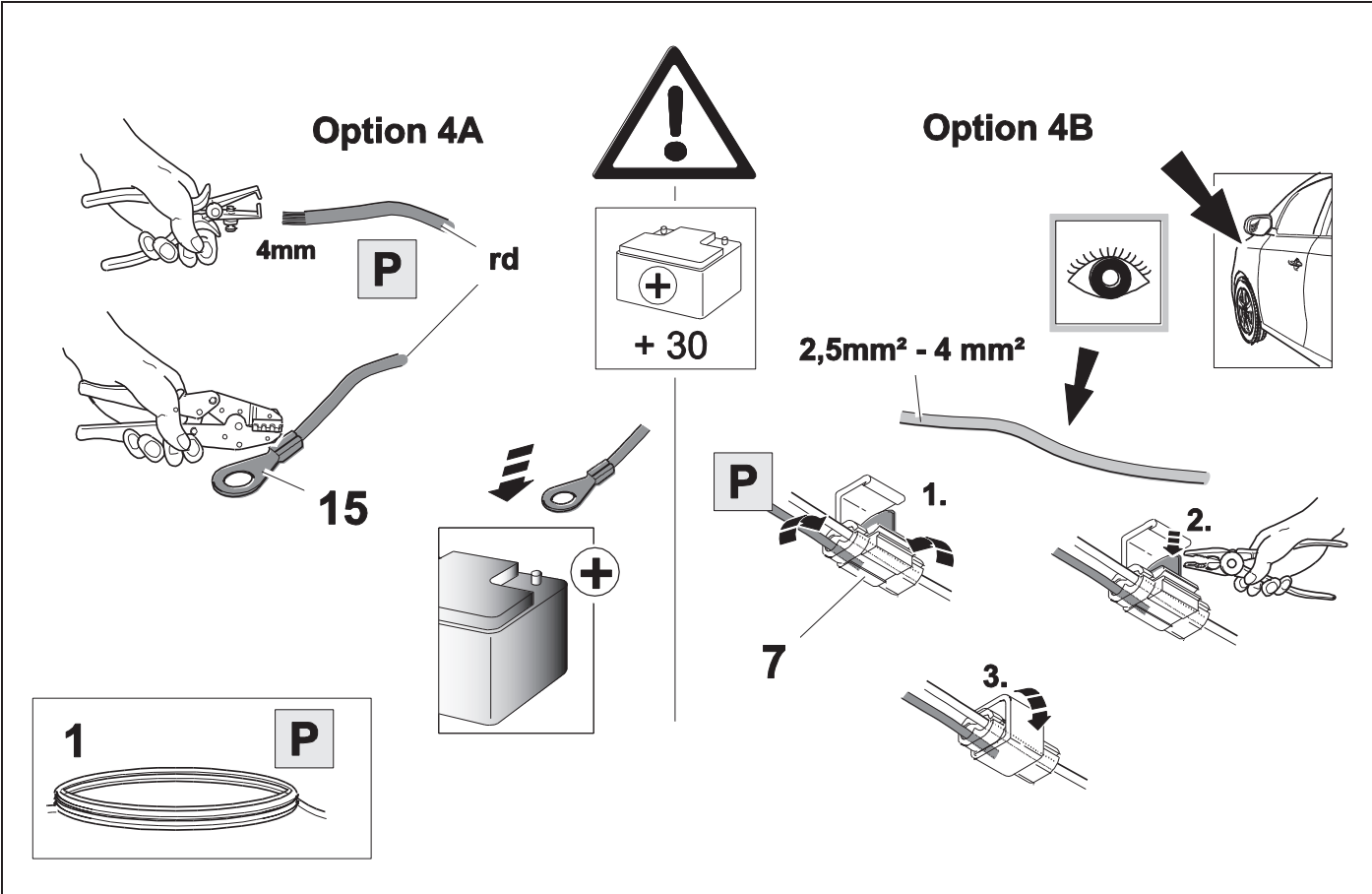

22 PARK DISTANCE CONTROL DEACTIVATION

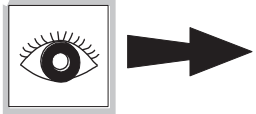
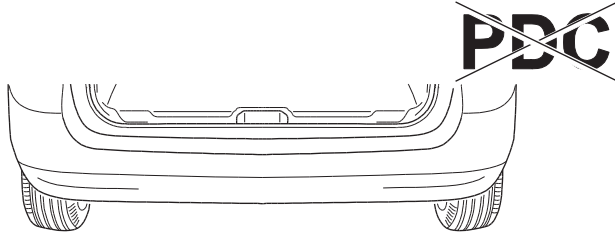

25 - 32

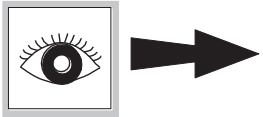
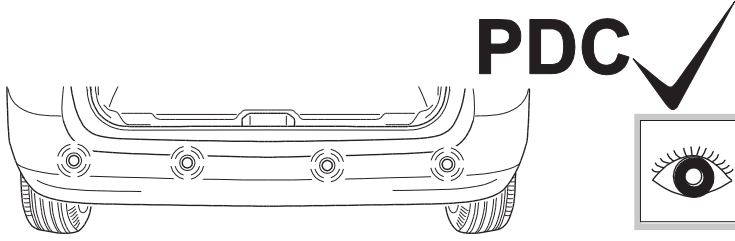

OPTION 5A

23

25 - 32

OPTION 5B

24

25 - 32

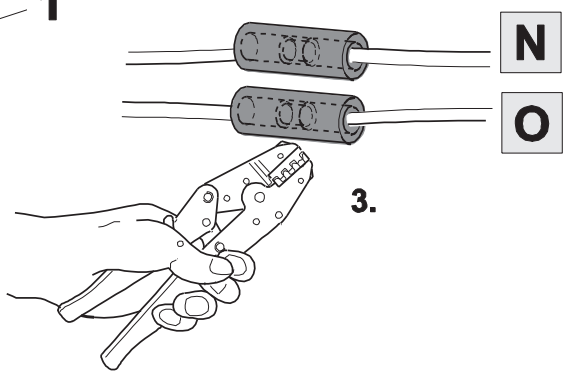
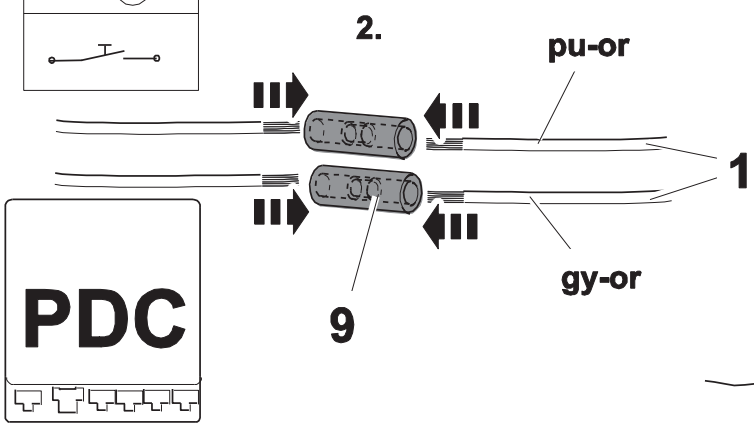
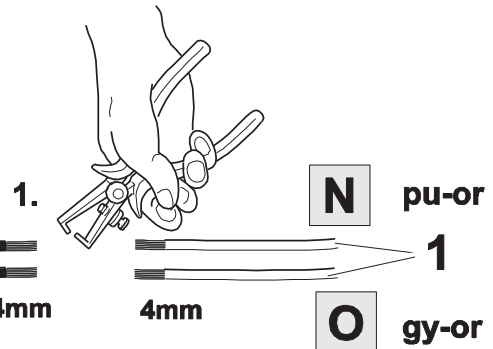
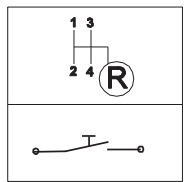
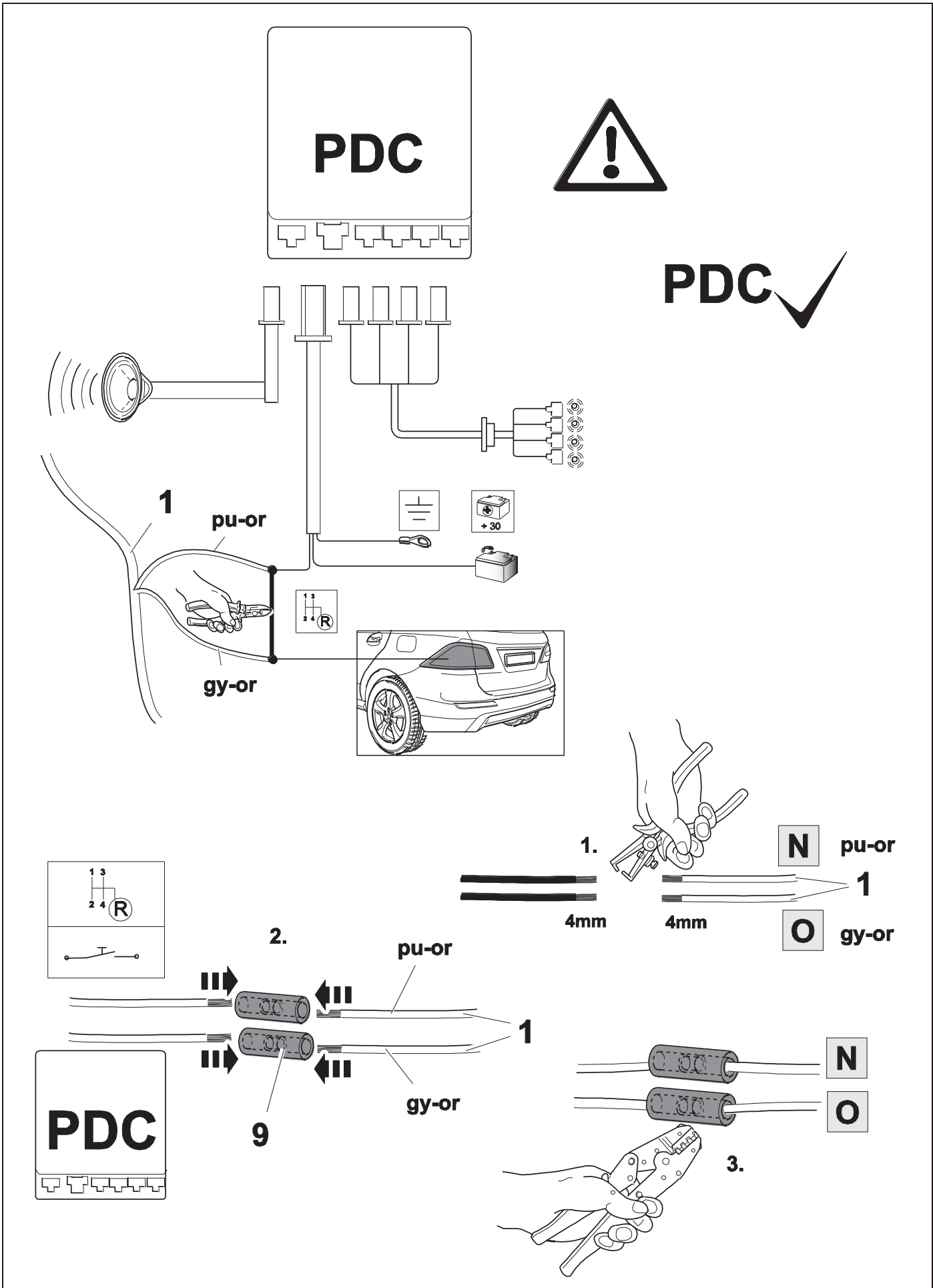

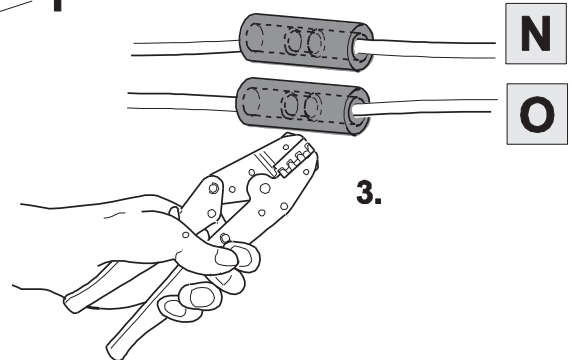
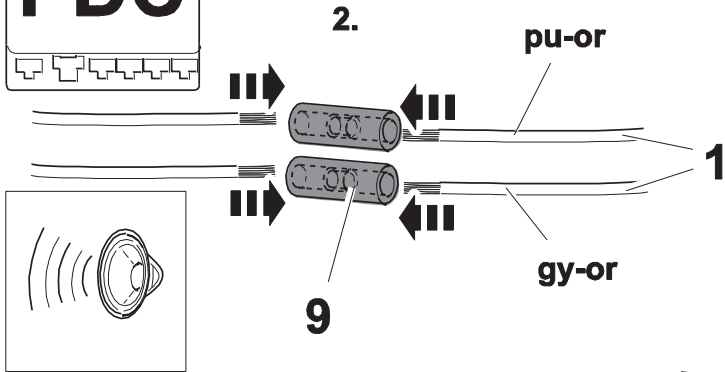
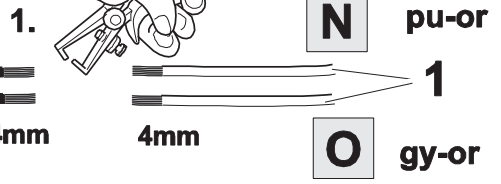
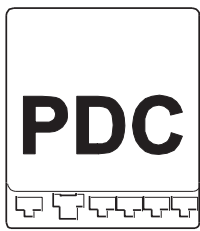
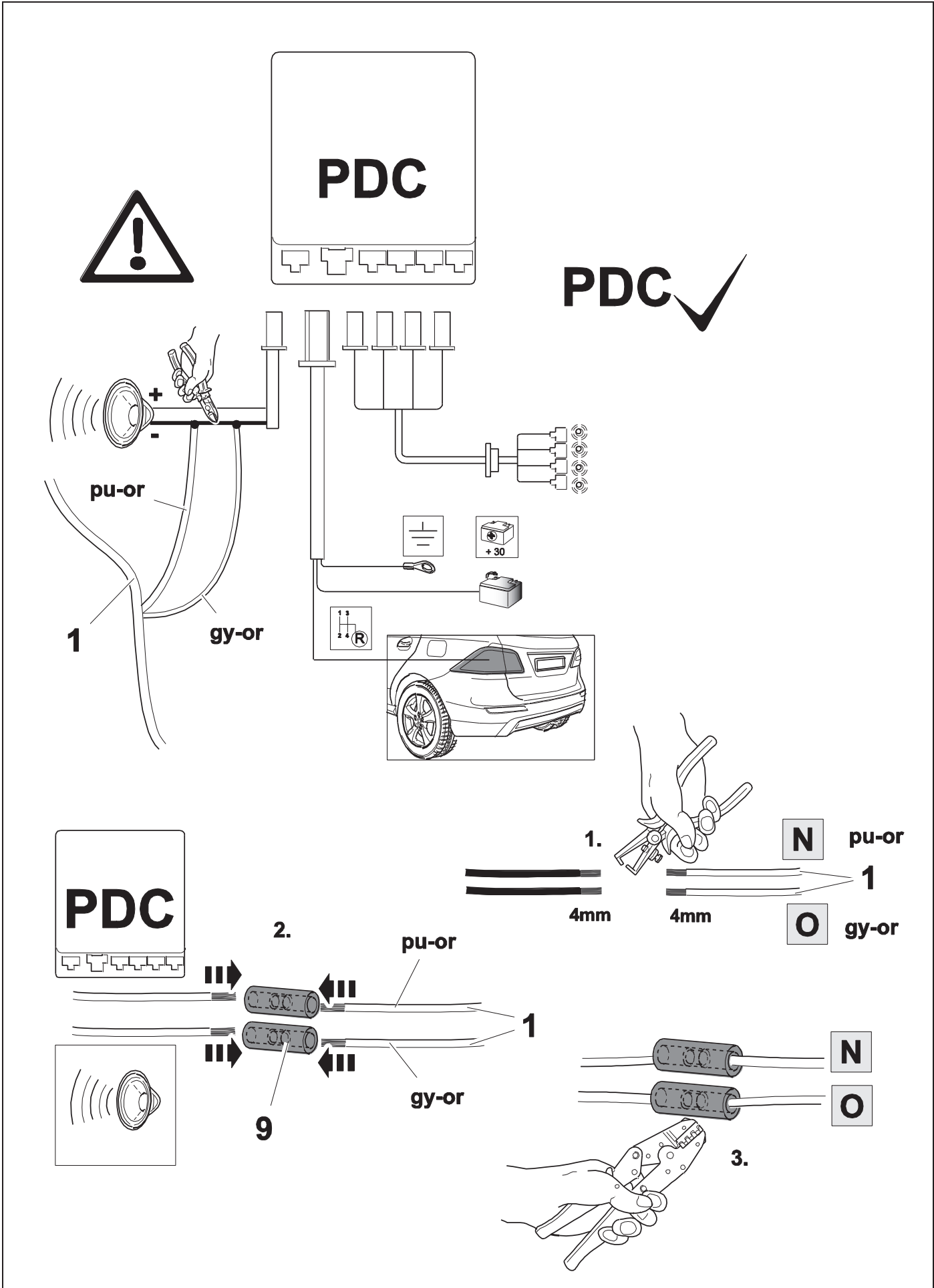

25

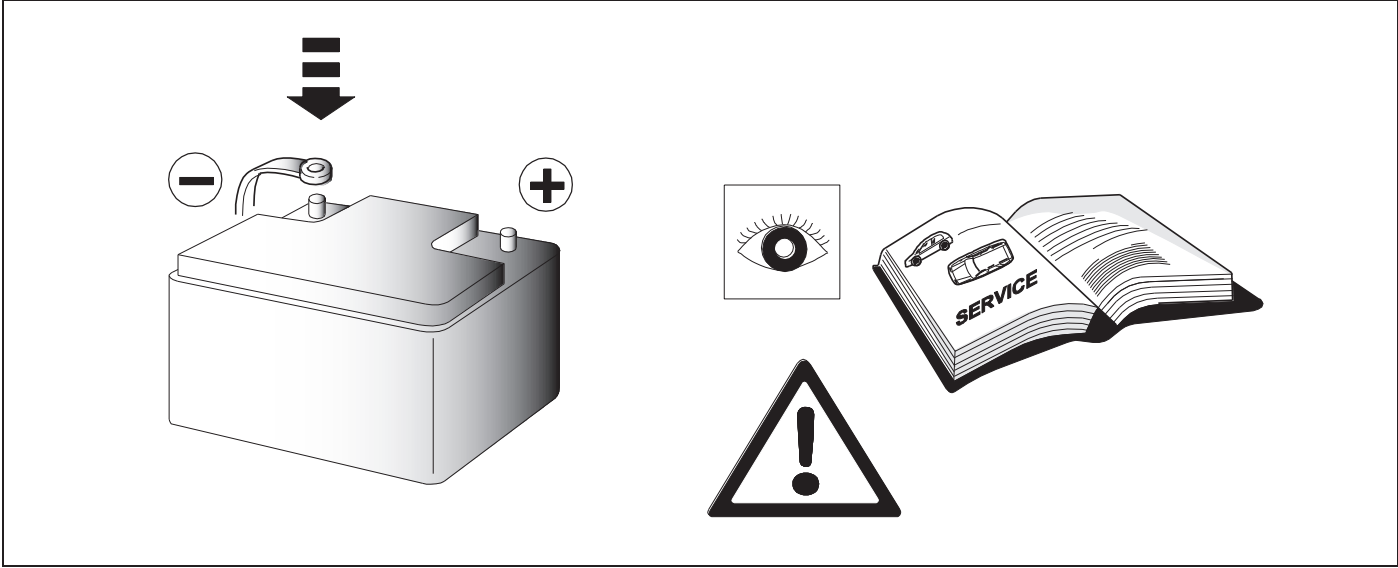

26

CHECK

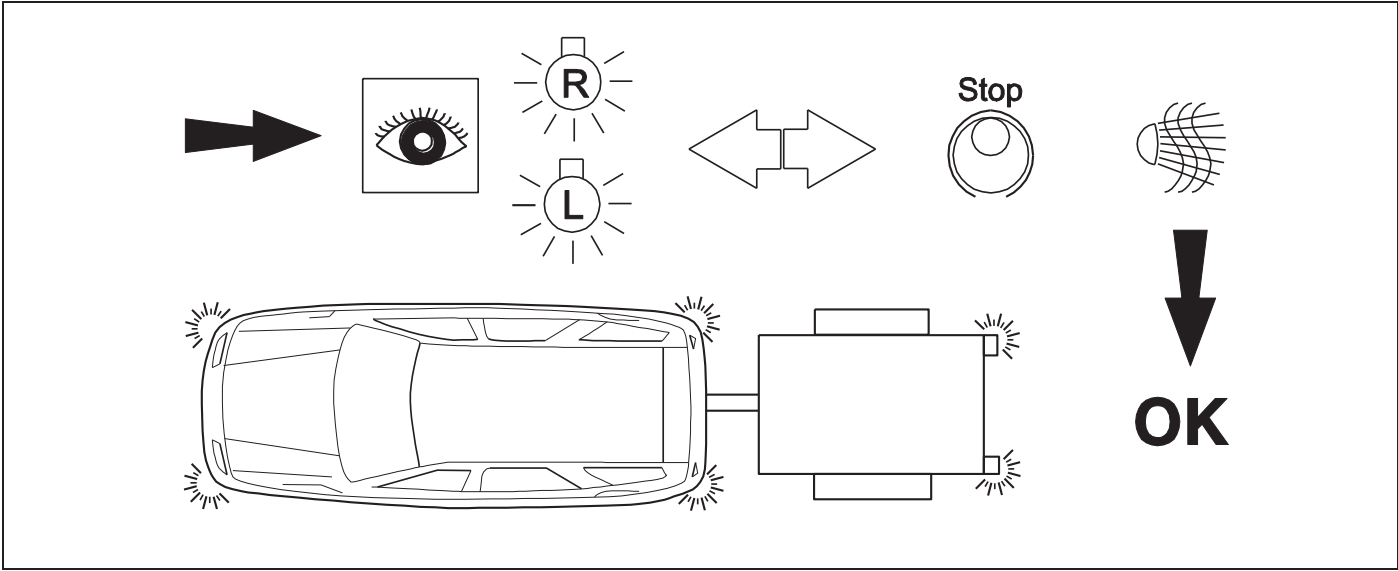

27 CHECK

 ⇒ **10**

FLASHER CONTROL

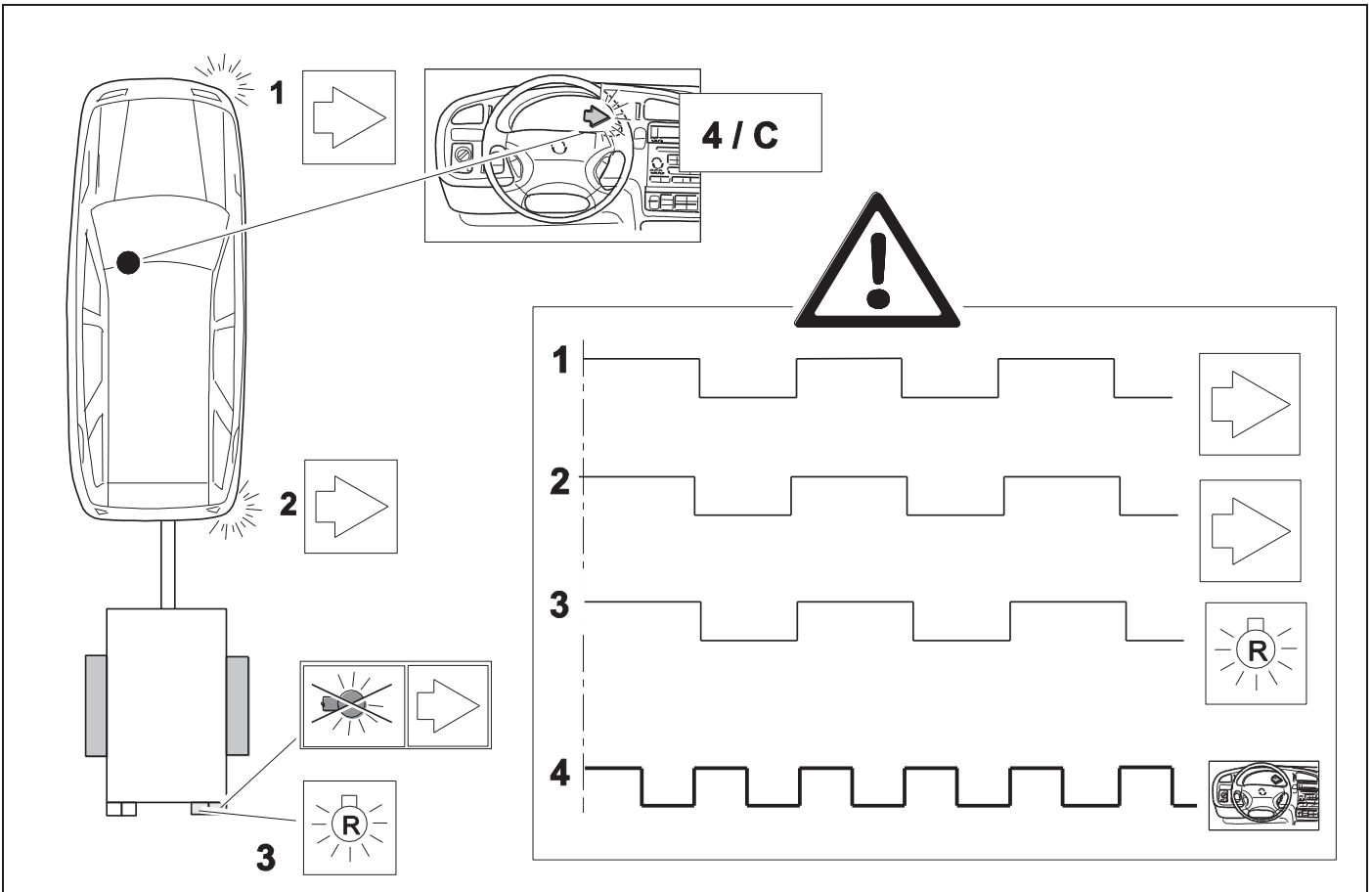

28 INFORMATION

 ⇒ **20**

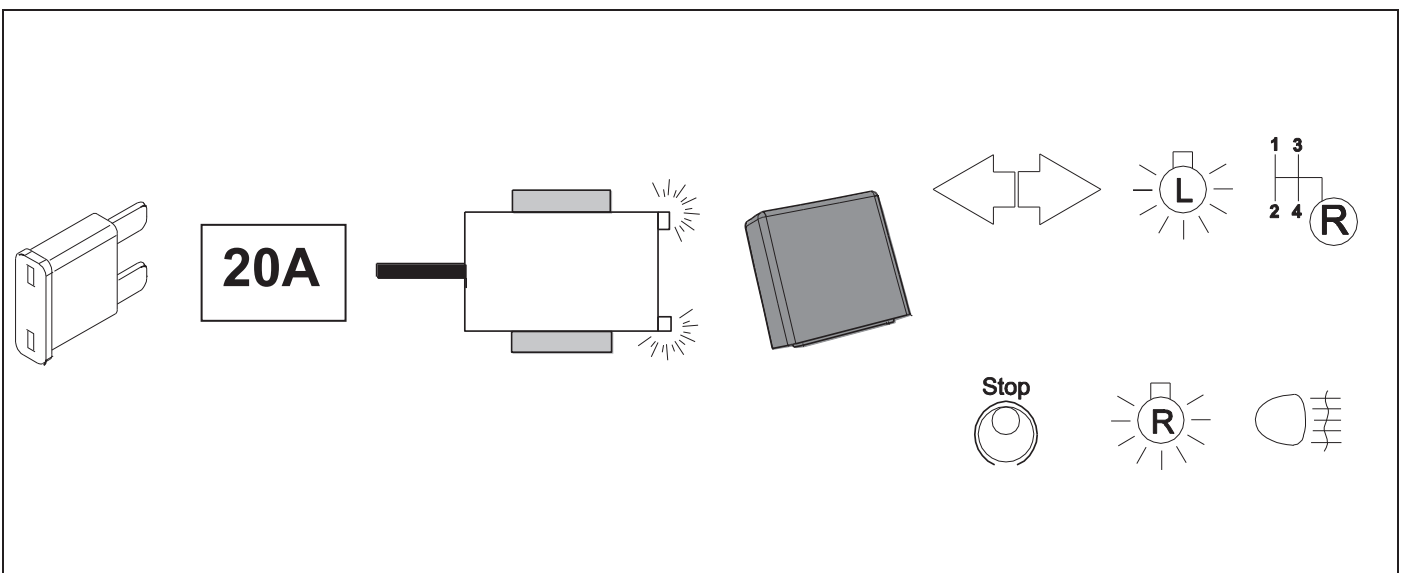

~~(D) (A) (GB)~~ 

(BUL) (CH) (CZ) (DK) (E) (EST) (F) (FIN) ✓
(H) (HR) (I) (LT) (LV) (N) (NL) (GR)
(RO) (RU) (S) (SK) (SLO) (TR) (P) (PL)

(D) (A) (GB) ✓ 

Use Extension Kit 721124

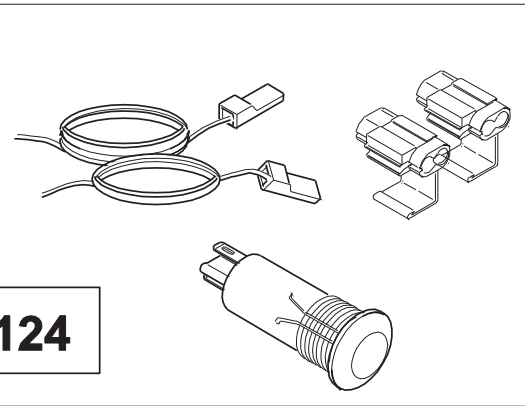

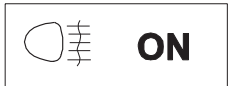

1.

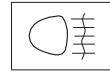
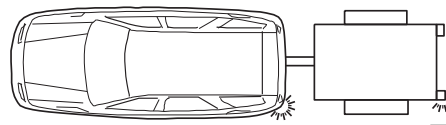
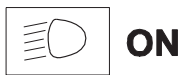
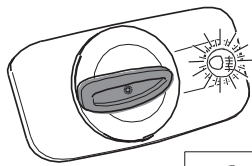

2.

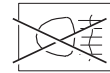
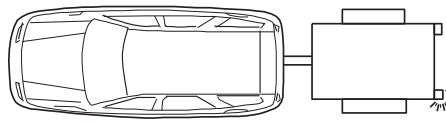
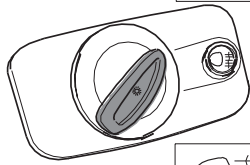

1.

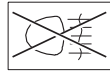
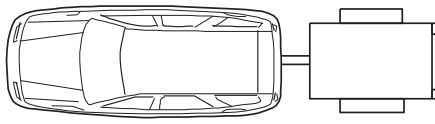
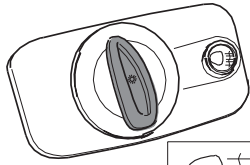

OPTION 1



1.

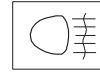
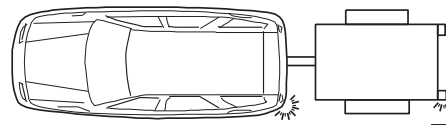
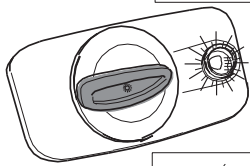

OPTION 2

2.

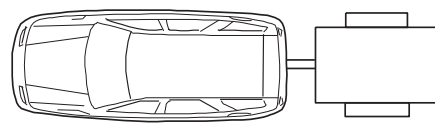
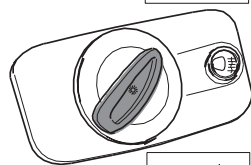

EXPERT SCHEMATIC WITHOUT TRAILER FLASHER CONTROL

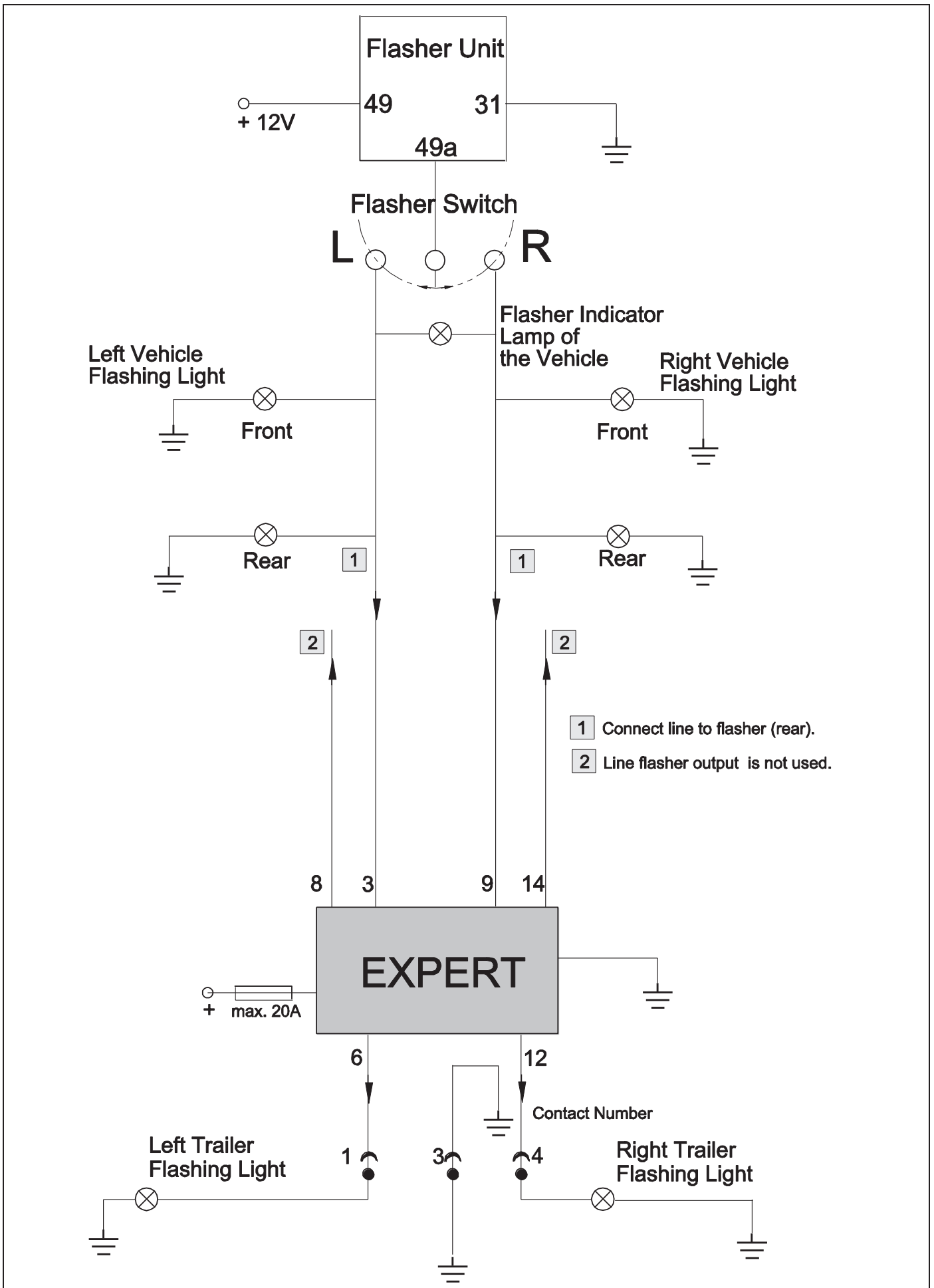

EXPERT SCHEMATIC WITH TRAILER FLASHER CONTROL

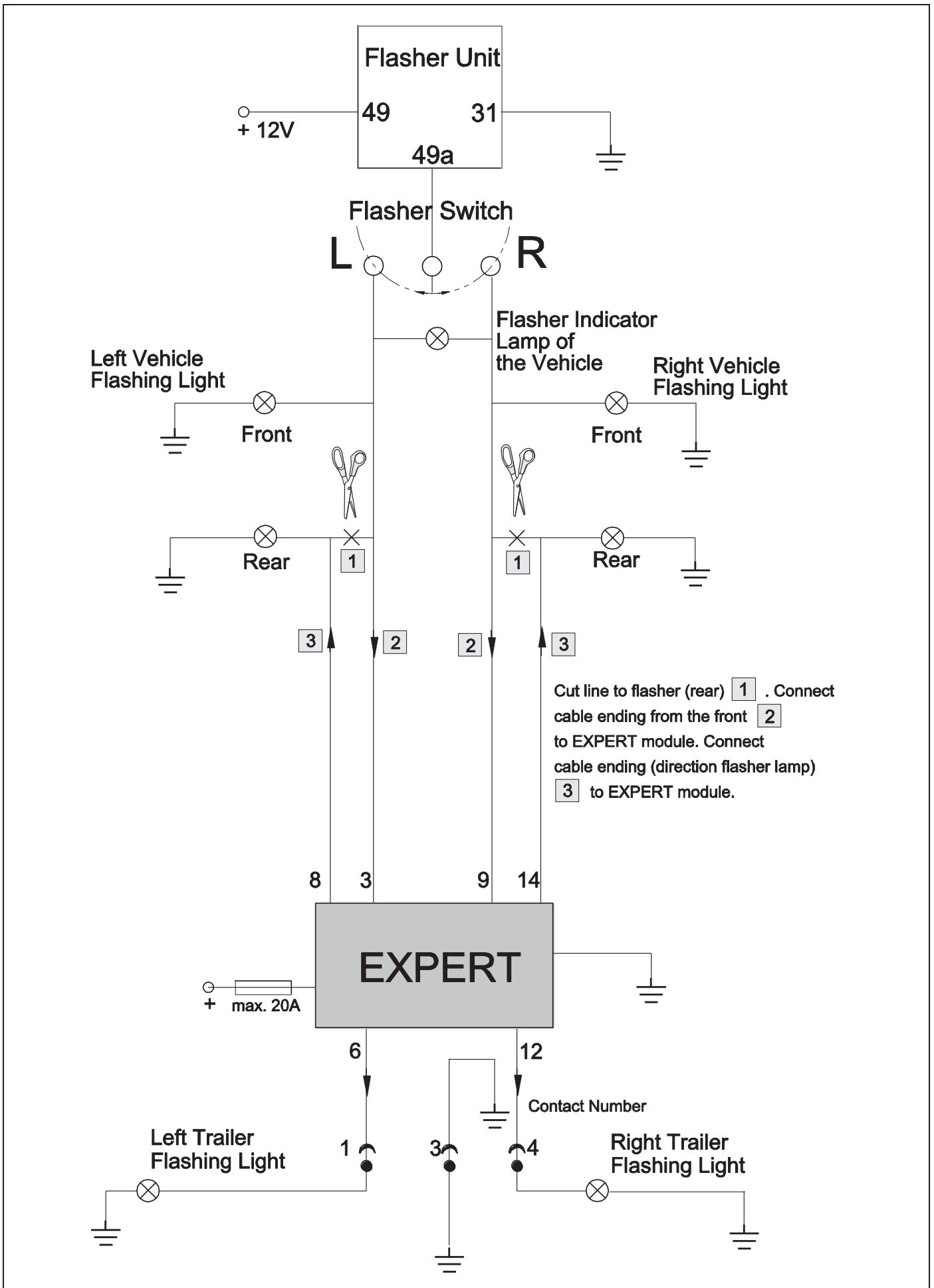

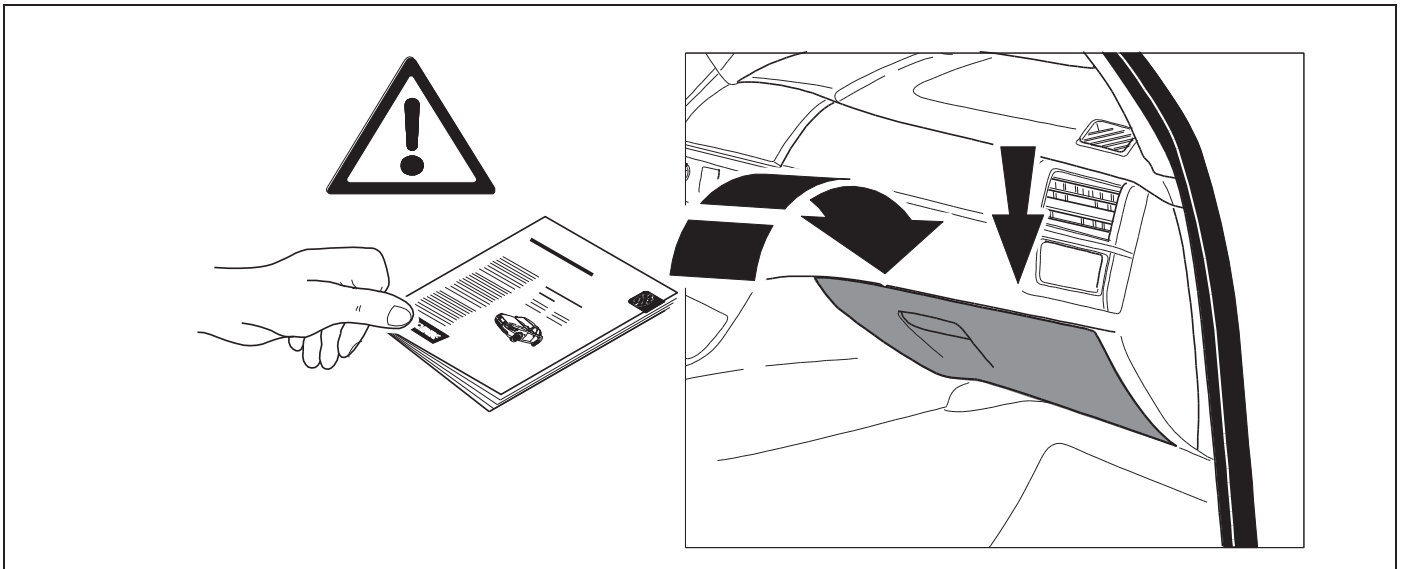

- | | |
|--|--|
| <p>(D) Änderungen bezüglich Konstruktion, Ausstattung Farbe sowie Irrtum vorbehalten. Angaben und Abbildungen unverbindlich</p> <p>(GB) Subject to change in terms of construction, equipment and colour, and may contain errors. The information and illustrations are non-binding.</p> <p>(F) Sous réserve de modifications de la construction, de l'équipement, de la couleur et sous réserve d'erreurs. Les indications et les illustrations sont sans engagement.</p> <p>(NL) Wijzigingen met betrekking tot constructie, uitvoering en kleur evenals vergissingen voorbehouden. Gegevens en afbeeldingen zijn niet bindend.</p> <p>(DK) Ændringer med hensyn til konstruktion, udstyr, farver samt fejl forbeholdes. Oplysninger og illustrationer er uforpligtende.</p> <p>(N) Endringer angående konstruksjon, utstyr, farge og feiltagelse forbeholdes. Opplysninger og illustrasjoner uforbindtlig.</p> <p>(S) Med reservation för ändringar vad det gäller konstruktion, utrustning, färg samt för misstag. Uppgifterna och bilderna är inte bindande.</p> <p>(FIN) Pidätämme oikeuden rakennetta, varustusta, väriä koskeviin sekä erehdyksestä johtuviin muutoksiin. Tiedot ja kuvat eivät ole sitovia.</p> <p>(I) Con riserva di modifiche relative a progettazione, dotazione, colore ed errori. Le indicazioni e figure sono fornite senza impegno.</p> <p>(E) Reservadas las modificaciones respecto a diseño, equipamiento, color, así como error. Indicaciones y figuras sin compromiso.</p> <p>(P) Reservamos o direito de alterações relativamente ao desenho, equipamento, cor, bem como de erro. Os dados e as gravuras não implicam compromisso da nossa parte.</p> <p>(GR) Διατηρούμε κάθε επιφύλαξη ως προς αλλαγές σε σχέση με κατασκευή, εξοπλισμό, διαρρύθμιση, χρωματισμούς και λάθη παραδρομής.</p> <p>(CZ) Změny, týkající se konstrukce, vybavení, barvy, jakož i omyly jsou vyhrazeny. Údaje a vyobrazení jsou nezávazné.</p> | <p>(PL) Zastrzega się prawo do zmian dot. konstrukcji, wykończenia, kolorystyki oraz pomyłek. Dane i ilustracje niewiążące.</p> <p>(TR) Tasarım, donanim ve renk bakımından deęişiklik yapma hakkı ve hata ve eksiklik mahfuzdur. Veriler ve resimler baęlayıcı deęildir.</p> <p>(H) A szerkezet, a kivitell és a szín változtatása, valamint a változások joga fenntartva. Az adatok és az ábrák nem kötelező érvényűek.</p> <p>(HR) Pravo promjena u svezi konstrukcije, opreme, boje kao i zabune oviđavamo. Podaci i ilustracije su neobavezne.</p> <p>(BUL) Запазени права по отношение на конструкцията, обзавеждането, цвета и грешки. Данните и изображенията не са обвързвачи.</p> <p>(RO) Ne rezervăm dreptul unor modificări ale construcției, dotării, culorii și dreptul la erori. Datele indicate și imaginile sunt orientative.</p> <p>(RU) Права на внесение изменений относительно конструкции, оснащения, окраски, а также на ошибки сохраняются. Данные и иллюстрации имеют примерный характер.</p> <p>(LT) Pasiliekaama konstrukcijos, įrangos bei reikmenų, spalvos pakeitimų ir klaidų teisė. Duomenys ir iliustracijos neįpareigojantys.</p> <p>(LV) Tiek paturētas tiesības uz konstrukcijas, iekārtu, krāsu izmaiņām, kā arī kļūdīšanās. Dati un attēli bez saistībām.</p> <p>(EST) Konstruktsiooni, varustuse ja võevi osas muudatused ning eksimine lubatud. Andmed ja joonised on mittesiduvad.</p> <p>(SLO) Zadržana pravica do sprememb glede konstrukcije, opreme, barve ter pomote. Podatki in slike so neobvezne.</p> <p>(SK) Zmeny, ktoré sa týkajú konštrukcie, vybavenia, farby, ako aj omyly sú vyhradené. Údaje a zobrazenia sú nezáväznú.</p> |
|--|--|